

Technical Information

Cerabar S PMC71, PMP71, PMP75

Process pressure measurement

Pressure transmitter with ceramic and metal sensors



Applications

The device is used for the following measuring tasks:

- Absolute pressure and gauge pressure measurement in gases, steams or liquids in all areas of process engineering and process measurement technology
- Level, volume or mass measurements in liquids
- High process temperatures
 - up to 150 °C (302 °F) without diaphragm seal
 - up to 400 °C (752 °F) with typical diaphragm seals
- High pressures up to 700 bar (10 500 psi)
- MID part certificate according to OIML R117-1 Edition 2007 (E) and EN 12405-1/A1 Edition 2006

Your benefits

- Very good reproducibility and long-term stability
- High reference accuracy up to $\pm 0.025\%$
- Turn down up to 100:1, higher on request
- Used for process pressure monitoring up to SIL 3, certified to IEC 61508 by TÜV SÜD
- High level of safety during operation thanks to function monitoring from the measuring cell to the electronics
- The patented TempC membrane for the diaphragm seal reduces measured errors caused by environmental and process temperature influences to a minimum
- Easy electronic replacement guaranteed with HistoROM®/M-DAT
- Uniform platform for differential pressure, hydrostatics and pressure (Deltabar S – Deltapilot S – Cerabar S)
- Practical user navigation for quick and easy commissioning
- Extensive diagnostic functions

HIGHLY CONFIGURABLE - Let Transcat Help build your Endress+Hauser Instrument
Call: **1.800.828.1470** or email **sales@transcat.com**

TRANSCAT[®]
Trust in every measure

Visit us at [Transcat.com](https://www.transcat.com) 

Endress + Hauser 
People for Process Automation

Table of contents

Document information	4	Total error	29
Document function	4	Warm-up period	29
Symbols used	4		
Documentation	5	Performance characteristics of the metallic process isolating diaphragm	30
Terms and abbreviations	5	Reference operating conditions	30
		Measuring uncertainty for small absolute pressure measuring ranges	30
Function and system design	7	Influence of the installation position	30
Device features	7	Resolution	30
Measuring principle	8	Reference accuracy	30
Product design	9	Thermal change of the zero output and the output span	32
Applications suitable for custody transfer measurement	9	Total performance	33
Communication protocol	10	Long-term stability	33
		Total error	33
Input	11	Warm-up period	33
Measured variable	11		
Measuring range	11	Installation	34
		General installation instructions	34
Output	14	Measuring arrangement for devices without diaphragm seals – PMC71, PMP71	34
Output signal	14	Measuring arrangement for devices with diaphragm seals – PMP75	34
Signal range 4 to 20 mA	14	Orientation	34
Signal on alarm	14	Wall and pipe mounting	34
Maximum load - 4 to 20 mA HART	15	Heat insulation – PMC71 high-temperature version	35
Dead time, time constant	15	Mounting of PVDF screw-in fittings	35
Dynamic behavior: current output	16	"Separate housing" version	36
Dynamic behavior: Digital output (HART electronics)	16	Turning the housing	37
Dynamic behavior: PROFIBUS PA	16	Oxygen applications	38
Dynamic behavior: FOUNDATION Fieldbus	17	Silicone-free applications	38
Damping	17	Ultrapure gas applications	38
Alarm current	18	Applications with hydrogen	38
Firmware version	18		
Protocol-specific data	18	Environment	39
		Ambient temperature range	39
Power supply	22	Storage temperature range	39
Terminal assignment	22	Degree of protection	39
Supply voltage	23	Climate class	39
Current consumption	23	Electromagnetic compatibility	39
Electrical connection	24	Vibration resistance	40
Terminals	24		
Cable entries	24	Process	41
Connector	24	Process temperature limits	41
Cable specification	25	Process temperature limits of flexible capillary armoring: PMP75	42
Start-up current	26	Pressure specifications	43
Residual ripple	26		
Oversvoltage protection (optional)	26	Mechanical construction	44
Influence of power supply	26	Device height	44
		T14 housing, optional display on the side	45
Performance characteristics of ceramic process isolating diaphragm	27	T17 housing (hygienic), optional display on the side	46
Reference operating conditions	27	Process connections for PMC71 with internal process isolating diaphragm	47
Measuring uncertainty for small absolute pressure measuring ranges	27	Process connections for PMC71 with internal process isolating diaphragm	49
Influence of the installation position	27		
Resolution	27		
Reference accuracy	27		
Thermal change of the zero output and the output span	28		
Total performance	28		
Long-term stability	28		





Process connections for PMC71 with internal process isolating diaphragm - height H	49	Planning instructions, diaphragm seal systems . . .	99
Process connections for PMC71 with flush-mounted process isolating diaphragm	50	Applications	99
Process connections for PMC71 with flush-mounted process isolating diaphragm	51	Design and operation mode	100
Process connections for PMC71 with flush-mounted process isolating diaphragm - height H	51	Diaphragm seal filling oils	101
Process connections for PMC71 with flush-mounted process isolating diaphragm	52	Information on cleaning	102
Hygienic process connections for PMC71 with flush-mounted process isolating diaphragm	55	Installation instructions	102
Process connections for PMP71 with internal process isolating diaphragm	57	Vacuum applications	104
Process connections for PMP71 with internal process isolating diaphragm	58	Certificates and approvals	105
Process connections for PMP71 with internal process isolating diaphragm	59	CE mark	105
Process connections for PMP71 with flush-mounted process isolating diaphragm	60	C-tick mark	105
Process connections for PMP71 with flush-mounted process isolating diaphragm	62	Ex approvals	105
Process connections for PMP71 with flush-mounted process isolating diaphragm	63	Suitable for hygiene applications	105
Process connections for PMP71 with flush-mounted process isolating diaphragm	64	Functional safety SIL/ IEC 61508 Declaration of Conformity (optional)	105
Process connections for PMP71 with flush-mounted process isolating diaphragm	65	Overfill protection	105
Process connections for PMP71	66	CRN approval	106
Process connections for PMP71	67	Other standards and guidelines	106
Process connections for PMP75 with flush-mounted process isolating diaphragm	68	Pressure Equipment Directive (PED)	106
PMP75 basic device	69	Marine approval	106
Process connections for PMP75 with flush-mounted process isolating diaphragm	70	Drinking water approval	106
Process connections for PMP75 with flush-mounted process isolating diaphragm	71	Approvals for custody transfer	107
Process connections for PMP75 with flush-mounted process isolating diaphragm	72	MID Parts Certificate	107
Hygienic process connections for PMP75 with flush-mounted process isolating diaphragm	73	Classification of process sealing between electrical systems and (flammable or combustible) process fluids in accordance with ANSI/ISA 12.27.01	107
Hygienic process connections for PMP75 with flush-mounted process isolating diaphragm	74	Inspection certificate	107
Hygienic process connections for PMP75 with flush-mounted process isolating diaphragm	76	Calibration	108
Process connections for PMP75 with flush-mounted process isolating diaphragm	79	Ordering information	109
Process connections for PMP75 with flush-mounted process isolating diaphragm	81	Scope of delivery	109
Process connections for PMP75	84	Configuration data sheet	109
Separate housing: Wall and pipe mounting with mounting bracket	86	Accessories	111
Materials not in contact with process	87	HistoROM®/M-DAT	111
Weight	90	Wall and pipe mounting	111
Materials in contact with process	90	Welding flanges and welding neck	111
Fill fluid	92	Supplementary documentation	112
Operability	93	Field of Activities	112
Operating concept	93	Technical Information	112
Local operation	93	Operating Instructions	112
Remote operation	96	Brief Operating Instructions	112
HistoROM®/M-DAT (optional)	97	Functional safety manual (SIL)	112
System integration	98	Overfill protection	112
		Safety Instructions (XA)	112
		Installation/Control Drawings	114
		Registered trademarks	115
		HART®	115
		PROFIBUS®	115
		FOUNDATION™ Fieldbus	115
		Patents	115

Document information







Document function	The document contains all the technical data on the device and provides an overview of the accessories and other products that can be ordered for the device.
--------------------------	---

Symbols used









Safety symbols

Symbol	Meaning
	DANGER! This symbol alerts you to a dangerous situation. Failure to avoid this situation will result in serious or fatal injury.
	WARNING! This symbol alerts you to a dangerous situation. Failure to avoid this situation can result in serious or fatal injury.
	CAUTION! This symbol alerts you to a dangerous situation. Failure to avoid this situation can result in minor or medium injury.
	NOTE! This symbol contains information on procedures and other facts which do not result in personal injury.

Electrical symbols

Symbol	Meaning	Symbol	Meaning
	Direct current		Alternating current
	Direct current and alternating current		Ground connection A grounded terminal which, as far as the operator is concerned, is grounded via a grounding system.
	Protective ground connection A terminal which must be connected to ground prior to establishing any other connections.		Equipotential connection A connection that has to be connected to the plant grounding system: This may be a potential equalization line or a star grounding system depending on national or company codes of practice.

Symbols for certain types of information

Symbol	Meaning
	Permitted Procedures, processes or actions that are permitted.
	Preferred Procedures, processes or actions that are preferred.
	Forbidden Procedures, processes or actions that are forbidden.
	Tip Indicates additional information.
	Reference to documentation
	Reference to page
	Reference to graphic
	Visual inspection

Symbols in graphics

Symbol	Meaning
1, 2, 3 ...	Item numbers
1., 2., 3. ...	Series of steps
A, B, C, ...	Views
A-A, B-B, C-C, ...	Sections

Documentation



The document types listed are available:
 In the Downloads area of the Endress+Hauser website: www.endress.com → Downloads

Brief Operating Instructions (KA): getting the 1st measured value quickly

The Brief Operating Instructions contain all the essential information from incoming acceptance to initial commissioning.

Operating Instructions (BA): your comprehensive reference

These Operating Instructions contain all the information that is required in various phases of the life cycle of the device: from product identification, incoming acceptance and storage, to mounting, connection, operation and commissioning through to troubleshooting, maintenance and disposal.

Description of Device Parameters (GP): reference for your parameters

The document provides a detailed explanation of each individual parameter in the operating menu. The description is aimed at those who work with the device over the entire life cycle and perform specific configurations.

Safety Instructions (XA)

See "Safety instructions" section → 112

Terms and abbreviations

Term/abbreviation	Explanation
BA	Document type "Operating Instructions"
KA	Document type "Brief Operating Instructions"
SD	Document type "Special Documentation"
XA	Document type "Safety Instructions"
PN	Nominal pressure
MWP	The MWP (maximum working pressure) for the individual sensors depends on the lowest-rated element, with regard to pressure, of the selected components, i.e. the process connection has to be taken into consideration in addition to the measuring cell. Also observe pressure-temperature dependency. For the relevant standards and additional information, see the "Pressure specifications" → 43 section. The MWP can also be found on the nameplate.
OPL	The OPL (over pressure limit = sensor overload limit) for the measuring device depends on the lowest-rated element, with regard to pressure, of the selected components, i.e. the process connection has to be taken into consideration in addition to the measuring cell. Also observe pressure-temperature dependency. For the relevant standards and additional information, see the "Pressure specifications" → 43 section.
LRL	Lower range limit
URL	Upper range limit
LRV	Lower range value
URV	Upper range value
TD	Turn down

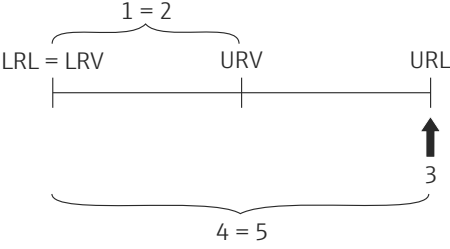
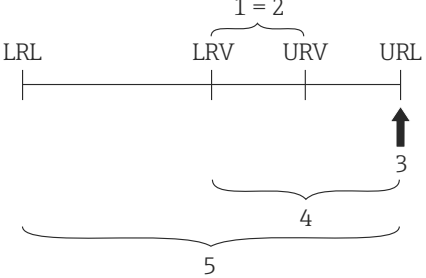
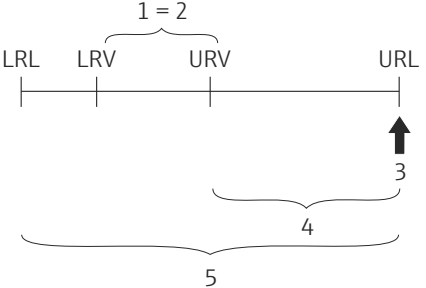
Term/abbreviation	Explanation
<p>Case 1 (1 bar (15 psi) measuring cell): Lower range value (LRV) \leq Upper range value (URV) Example:</p> <ul style="list-style-type: none"> ▪ Lower range value (LRV) = 0 bar ▪ Upper range value (URV) = 0.5 bar (7.5 psi) ▪ Nominal value (URL) = 1 bar (15 psi) <p>Turn down: TD = URL / URV = 2:1 Set span: URV - LRV = 0.5 bar (7.5 psi) This span is based on the zero point.</p>	 <p style="text-align: right;">A0019780</p>
<p>Case 2 (1 bar (15 psi) measuring cell): Lower range value (LRV) \leq Upper range value (URV) Example:</p> <ul style="list-style-type: none"> ▪ Lower range value (LRV) = 0 bar ▪ Upper range value (URV) = 0.5 bar (7.5 psi) ▪ Nominal value (URL) = 1 bar (15 psi) <p>Turn down: TD = URL / URV = 2:1 Set span: URV - LRV = 0.5 bar (7.5 psi) This span is based on the zero point.</p>	 <p style="text-align: right;">A0019783</p>
<p>Case 3 (1 bar (15 psi) measuring cell): Lower range value (LRV) \geq Upper range value (URV) Example:</p> <ul style="list-style-type: none"> ▪ Lower range value (LRV) = -0.6 bar (-9 psi) ▪ Upper range value (URV) = 0 bar ▪ Nominal value (URL) = 1 bar (15 psi) <p>Turn down: TD = URL / LRV = 1.67:1 Set span: URV - LRV = 0.6 bar (9 psi) This span is based on the zero point.</p>	 <p style="text-align: right;">A0016451</p> <p>1 Set span 2 Zero-based span 3 Nominal value \cong Upper range limit (URL) 4 Nominal measuring range 5 Sensor measuring range</p>

Function and system design

Device features

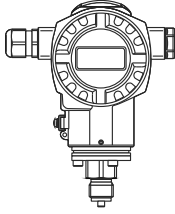
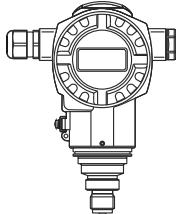
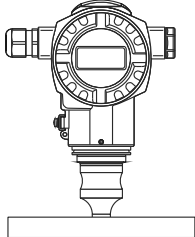
	PMC71	PMP71	PMP75
	 A0020461	 A0020463	 A0020464
	With capacitive measuring cell and ceramic process isolating diaphragm (Ceraphire®)	With piezoresistive measuring cell and metallic welded process isolating diaphragm	With diaphragm seal
Field of application	<ul style="list-style-type: none"> ■ Gauge pressure and absolute pressure ■ Level 		
Process connections	<ul style="list-style-type: none"> ■ Diverse thread ■ DN 25 – DN 80 ■ ASME 1 ½" – 4" ■ JIS 50 A – 100 A 	<ul style="list-style-type: none"> ■ Diverse thread ■ DN 25 – DN 80 ■ ASME 1 ½" – 4" ■ JIS 25 A – 100 A ■ Oval flange adapter ■ Prepared for diaphragm seal mount 	Wide range of diaphragm seals
Measuring ranges	from –100/0 to 100 mbar (–1.5/0 to 1.5 psi) to –1/0 to 40 bar (–15/0 to 600 psi)	from –400/0 to 400 mbar (–6/0 to 6 psi) to –1/0 to 700 bar (–15/0 to 10500 psi)	from –400/0 to 400 mbar (–6/0 to 6 psi) to –1/0 to 400 bar (–15/0 to 6000 psi)
OPL	max. 60 bar (900 psi)	max. 1 050 bar (15 750 psi)	max. 600 bar (9 000 psi)
Process temperature range (temperature at process connection)	–25 to +125 °C (–13 to +257 °F) / –20 to +150 °C (–4 to +302 °F) ¹⁾	–40 to +125 °C (–40 to +257 °F)	–70 to +400 °C (–94 to +752 °F) (depends on filling oil)
Ambient temperature range	<ul style="list-style-type: none"> ■ Without LCD display: –40 to +85 °C (–40 to +185 °F) ²⁾ ■ With LCD display: –20 to +70 °C (–4 to +158 °F) ■ Separate housing: –20 to +60 °C (–4 to +140 °F) ■ Diaphragm seal systems depending on the version 		
Reference accuracy	<ul style="list-style-type: none"> ■ Up to ±0.05 % of the set span ■ PLATINUM version: up to ±0.025 % of the set span 		Up to ±0.075 % of the set span
Supply voltage non-Ex	<ul style="list-style-type: none"> ■ 4 to 20 mA HART: 10.5 to 45 V DC ■ PROFIBUS PA and FOUNDATION Fieldbus: 9 to 32 V DC 		
Supply voltage Ex ia	10.5 to 30 V DC		
Output	4 to 20 mA with superimposed HART protocol, PROFIBUS PA or FOUNDATION Fieldbus		
Options	<ul style="list-style-type: none"> ■ Gold-rhodium coated process isolating diaphragm ■ NACE-compliant materials 		
	<ul style="list-style-type: none"> ■ Inspection certificate 3.1 ■ HistoROM®/M-DAT memory chip ■ Separate housing 		
Specialties	<ul style="list-style-type: none"> ■ Metal-free measurement with PVDF connection ■ Special cleaning of the transmitter to remove paint-wetting substances, for use in paint shops 	<ul style="list-style-type: none"> ■ Process connections with minimum oil volume ■ Gas-tight, elastomer-free 	<ul style="list-style-type: none"> ■ Wide range of diaphragm seals ■ For high media temperatures ■ Process connections with minimum oil volume ■ Completely welded versions

1) High-temperature version, see Product Configurator section "Additional options 1" or 110 "Additional options 2", option "T"

2) PMP71 and PMP75: lower temperatures on request

Measuring principle

Devices with ceramic process isolating diaphragm (Ceraphire®)

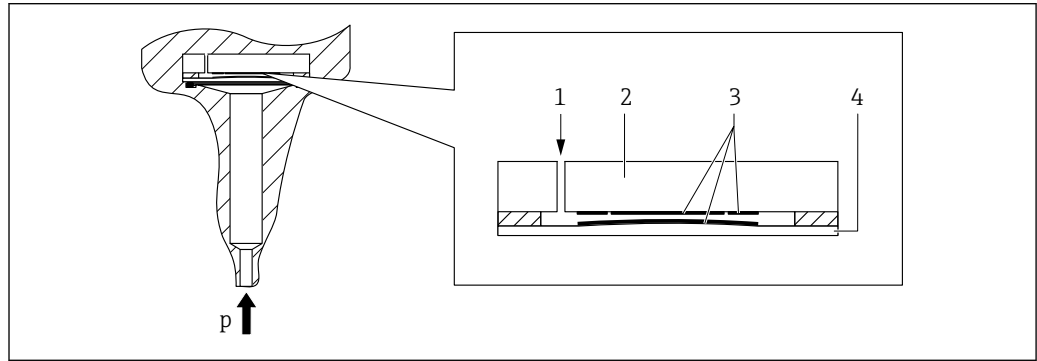

A0020465

- 1 Air pressure (relative pressure sensors)
- 2 Ceramic substrate
- 3 Electrodes
- 4 Ceramic process isolating diaphragm

The ceramic sensor is an oil-free sensor, i.e. the process pressure acts directly on the robust ceramic process isolating diaphragm and causes it to deflect. A pressure-dependent change in capacitance is measured at the electrodes of the ceramic substrate and the process isolating diaphragm. The measuring range is determined by the thickness of the ceramic process isolating diaphragm.

Advantages:

- Guaranteed overload resistance up to 40 times the nominal pressure (see "OPL" column in table) → ☰ 11)
- The ultrapure 99.9% ceramic (Ceraphire®, see also "www.endress.com/ceraphire") ensures:
 - Extremely high chemical durability
 - Less relaxation
 - High mechanical durability
- Suitable for vacuums
- Secondary containment for enhanced integrity
- Process temperatures up to 150 °C (302 °F)

Devices with metallic process isolating diaphragm

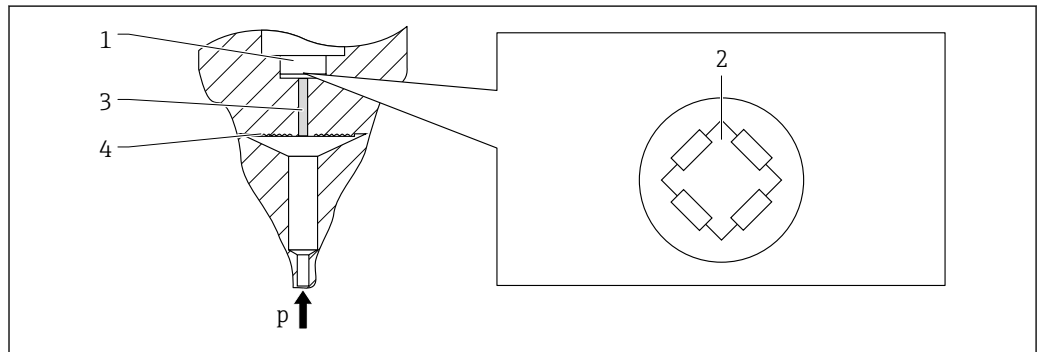

A0016448

- 1 Silicon measuring element, substrate
- 2 Wheatstone bridge
- 3 Channel with fill fluid
- 4 Metal process isolating diaphragm

PMP71

The process pressure deflects the metal process isolating diaphragm of the sensor and a fill fluid transfers the pressure to a Wheatstone bridge (semiconductor technology). The pressure-dependent change in the bridge output voltage is measured and evaluated.

Advantages:

- Can be used for process pressures up to 700 bar (10 500 psi)
- High long-term stability
- Guaranteed overload resistance up to 4 times the nominal pressure
- Secondary containment for enhanced integrity
- Significantly reduced thermal effect e.g. compared to diaphragm seal systems with capillaries

PMP75

The operating pressure acts on the process isolating diaphragm of the diaphragm seal and is transferred to the process isolating diaphragm of the sensor by a diaphragm seal fill fluid. The process isolating diaphragm is deflected and a fill fluid transfers the pressure to a resistance measuring bridge. The pressure-dependent change in the bridge output voltage is measured and evaluated.

Advantages:

- Depending on the version, can be used for process pressures up to 400 bar (6 000 psi) and for extreme process temperatures
- High long-term stability
- Guaranteed overload resistance up to 4 times the nominal pressure
- Secondary containment for enhanced integrity

Product design

Level measurement (level, volume and mass):

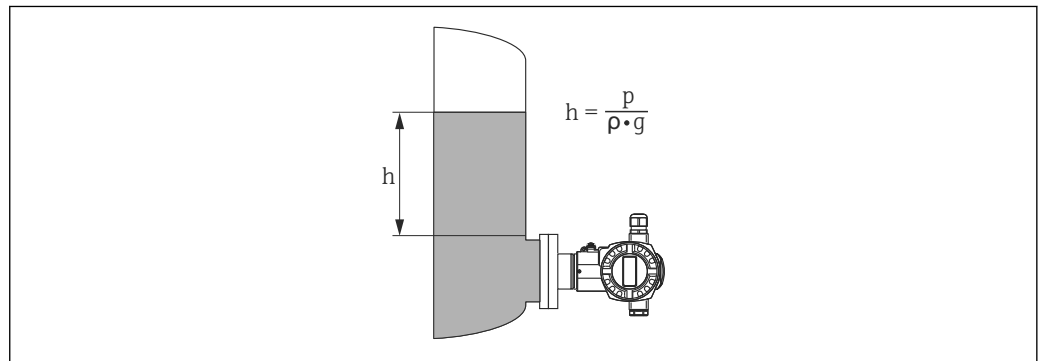

A0020466

- h* Height (level)
- p* Pressure
- ρ* Density of the medium
- g* Gravitational constant

Your benefits

- Selection of the level operating mode which is optimum for your application in the device software.
- Volume and mass measurements in any container shapes by means of a freely programmable characteristic curve.
- Choice of diverse level units with automatic unit conversion.
- A customized unit can be specified.
- Has a wide range of uses, e.g.
 - in the event of foam formation
 - in containers with agitators or screen fittings
 - in the event of liquid gases

Applications suitable for custody transfer measurement

The Parts Certificate is issued on the basis of the following standards:

- WELMEC guide 8.8 "General and Administrative Aspects of the Voluntary System of Modular Evaluation of Measuring instruments under the MID".
- OIML R117-1 Edition 2007 (E) "Dynamic measuring systems for liquids other than water".
- EN 12405-1/A1 Edition 2006 "Gas meters – Conversion devices – Part 1: Volume conversion".

Communication protocol

- 4 to 20 mA with HART communication protocol
- PROFIBUS PA
 - The Endress+Hauser devices meet the requirements of the FISCO model.
 - Due to a low current consumption of $13 \text{ mA} \pm 1 \text{ mA}$, the following number of devices can be operated on one bus segment if installing as per FISCO: up to 7 devices for Ex ia, CSA IS and FM IS applications or up to 27 devices for all other applications e.g. in non-hazardous areas, Ex nA etc.
Further information on PROFIBUS PA can be found in Operating Instructions BA00034S "PROFIBUS DP/PA: Guidelines for planning and commissioning" and in the PNO Guideline.
- FOUNDATION Fieldbus
 - The Endress+Hauser devices meet the requirements of the FISCO model.
 - Due to a low current consumption of $15.5 \text{ mA} \pm 1 \text{ mA}$, the following number of devices can be operated on one bus segment if installing as per FISCO: up to 6 devices for Ex ia, CSA IS and FM IS applications or up to 24 devices for all other applications e.g. in non-hazardous areas, Ex nA etc.
Further information on FOUNDATION Fieldbus, such as requirements for bus system components, can be found in Operating Instructions BA00013S "FOUNDATION Fieldbus Overview".

Input

Measured variable

Measured process variables

- Absolute pressure
- Gauge pressure

Calculated process variables

Level (level, volume or mass)

Measuring range

PMC71 – with ceramic process isolating diaphragm (Ceraphire®) for gauge pressure

Nominal value	Range limit		Lowest calibratable Span ¹⁾	MWP	OPL	Vacuum resistance	Option ²⁾
	lower (LRL)	upper (URL)					
	[bar (psi)]	[bar (psi)]					
100 mbar (1.5 psi)	-0.1 (-1.5)	+0.1 (+1.5)	0.005 (0.075)	2.7 (40.5)	4 (60)	0.7 (10.5)	1C
250 mbar (3.75 psi)	-0.25 (-4)	+0.25 (+4)	0.005 (0.075)	3.3 (49.5)	5 (75)	0.5 (7.5)	1E
400 mbar (6 psi)	-0.4 (-6)	+0.4 (+6)	0.005 (0.075)	5.3 (79.5)	8 (120)	0	1F
1 bar (15 psi)	-1 (-15)	+1 (+15)	0.01 (0.15)	6.7 (100.5)	10 (150)	0	1H
2 bar (30 psi)	-1 (-15)	+2 (+30)	0.02 (0.3)	12 (180)	18 (270)	0	1K
4 bar (60 psi)	-1 (-15)	+4 (+60)	0.04 (0.6)	16.7 (250.5)	25 (375)	0	1M
10 bar (150 psi)	-1 (-15)	+10 (+150)	0.1 (1.5)	26.7 (400.5)	40 (600)	0	1P
40 bar (600 psi)	-1 (-15)	+40 (+600)	0.4 (6)	40 (600)	60 (900)	0	1S

- 1) Turndown > 100:1 on request or can be set on device
- 2) Product Configurator, order code for "Sensor range; sensor over pressure limit"

PMC71 – with ceramic process isolating diaphragm (Ceraphire®) for absolute pressure

Nominal value	Range limit		Lowest calibratable Span ¹⁾	MWP	OPL	Vacuum resistance	Option ²⁾
	lower (LRL)	upper (URL)					
	[bar (psi)]	[bar (psi)]					
100 mbar (1.5 psi)	0	+0.1 (+1.5)	0.005 (0.075)	2.7 (40.5)	4 (60)	0	2C
250 mbar (3.75 psi)	0	+0.25 (+4)	0.005 (0.075)	3.3 (49.5)	5 (75)	0	2E
400 mbar (6 psi)	0	+0.4 (+6)	0.005 (0.075)	5.3 (79.5)	8 (120)	0	2F
1 bar (15 psi)	0	+1 (+15)	0.01 (0.15)	6.7 (100.5)	10 (150)	0	2H
2 bar (30 psi)	0	+2 (+30)	0.02 (0.3)	12 (180)	18 (270)	0	2K
4 bar (60 psi)	0	+4 (+60)	0.04 (0.6)	16.7 (250.5)	25 (375)	0	2M
10 bar (150 psi)	0	+10 (+150)	0.1 (1.5)	26.7 (400.5)	40 (600)	0	2P
40 bar (600 psi)	0	+40 (+600)	0.4 (6)	40 (600)	60 (900)	0	2S

- 1) Turndown > 100:1 on request or can be set on device
- 2) Product Configurator, order code for "Sensor range; sensor over pressure limit"

PMP71 and PMP75 – metallic process isolating diaphragm for gauge pressure

Nominal value	Range limit		Lowest calibratable Span ¹⁾	MWP	OPL	Vacuum resistance ²⁾	Option ³⁾
	lower (LRL)	upper (URL)				Silicone oil/ Inert oil	
	[bar (psi)]	[bar (psi)]				[bar _{abs} (psi _{abs})]	
400 mbar (6 psi)	-0.4 (-6)	+0.4 (+6)	0.005 (0.075)	4 (60)	6 (90)	0.01/0.04 (0.15/0.6)	1F
1 bar (15 psi)	-1 (-15)	+1 (+15)	0.01 (0.15)	6.7 (100)	10 (150)		1H
2 bar (30 psi)	-1 (-15)	+2 (+30)	0.02 (0.3)	13.3 (200)	20 (300)		1K
4 bar (60 psi)	-1 (-15)	+4 (+60)	0.04 (0.6)	18.7 (280.5)	28 (420)		1M
10 bar (150 psi)	-1 (-15)	+10 (+150)	0.1 (1.5)	26.7 (400.5)	40 (600)		1P
40 bar (600 psi)	-1 (-15)	+40 (+600)	0.4 (6)	100 (1500)	160 (2400)		1S
100 bar (1500 psi)	-1 (-15)	+100 (+1500)	1.0 (15)	100 (1500)	400 (6000)		1U
400 bar (6000 psi)	-1 (-15)	+400 (+6000)	4.0 (60)	400 (6000)	600 (9000)		1W
700 bar (10500 psi) ⁴⁾	-1 (-15)	+700 (+10500)	7.0 (105)	700 (10500)	1050 (15750)		1X

- 1) Turndown > 100:1 on request or can be set on device
- 2) The vacuum resistance applies to the measuring cell under reference operating conditions. In the case of the PMP75, the pressure and temperature application limits of the selected filling oil must also be observed .
- 3) Product Configurator, order code for "Sensor range; sensor over pressure limit"
- 4) PMP71 only, PMP75 on request

PMP71 and PMP75 – metallic process isolating diaphragm for absolute pressure

Nominal value	Range limit		Lowest calibratable Span ¹⁾	MWP	OPL	Vacuum resistance ²⁾	Option ³⁾
	lower (LRL)	upper (URL)				Silicone oil/ Inert oil	
	[bar (psi)]	[bar (psi)]				[bar _{abs} (psi _{abs})]	
400 mbar (6 psi)	0	+0.4 (+6)	0.005 (0.075)	4 (60)	6 (90)	0.01/0.04 (0.15/0.6)	2F
1 bar (15 psi)	0	+1 (+15)	0.01 (0.15)	6.7 (100)	10 (150)		2H
2 bar (30 psi)	0	+2 (+30)	0.02 (0.3)	13.3 (200)	20 (300)		2K
4 bar (60 psi)	0	+4 (+60)	0.04 (0.6)	18.7 (280.5)	28 (420)		2M
10 bar (150 psi)	0	+10 (+150)	0.1 (1.5)	26.7 (400.5)	40 (600)		2P
40 bar (600 psi)	0	+40 (+600)	0.4 (6)	100 (1500)	160 (2400)		2S
100 bar (1500 psi)	0	+100 (+1500)	1.0 (15)	100 (1500)	400 (6000)		2U
400 bar (6000 psi)	0	+400 (+6000)	4.0 (60)	400 (6000)	600 (9000)		2W
700 bar (10500 psi) ⁴⁾	0	+700 (+10500)	7.0 (105)	700 (10500)	1050 (15750)		2X

- 1) Turndown > 100:1 on request or can be set on device
- 2) The vacuum resistance applies to the measuring cell under reference operating conditions. In the case of the PMP75, the pressure and temperature application limits of the selected filling oil must also be observed .
- 3) Product Configurator, order code for "Sensor range; sensor over pressure limit"
- 4) PMP71 only, PMP75 on request

PMP71 - metallic process isolating diaphragms for absolute pressure with MID parts certificate

Nominal value	Range limit		Min. WP for gas applications suitable for custody transfer measurement	Min. WP for liquid applications suitable for custody transfer measurement	MWP	OPL	Vacuum resistance ¹⁾	Option ²⁾
	lower (LRL) ³⁾	upper (URL) ⁴⁾					Silicone oil/ Inert oil	
[bar (psi)]	[bar (psi)]	[bar (psi)]	[bar (psi)]	[bar (psi)]	[bar (psi)]	[bar (psi)]	[bar (psi)]	
10 (150)	0	+10 (150)	0.5 (7.5)	0.5 (7.5)	26.7 (400.5)	40 (600)	0.01/0.04 (0.15/1)	MP
50 (750)	0	+50 (750)	10 (150)	2.5 (37.5)	100 (1500)	400 (6000)	0.01/0.04 (0.15/1)	MT
100 (1500)	0	+100 (1500)	5 (75)	5 (75)	100 (1500)	400 (6000)	0.01/0.04 (0.15/1)	MU

- 1) The vacuum resistance applies to the measuring cell under reference operating conditions
- 2) Product Configurator, order code for "Sensor range; sensor over pressure limit"
- 3) By default, the device is set to a lower range limit of 0 bar. Please specify in the order if the lower range limit is to be set to a different default value.
- 4) Max. WP for gas and liquid applications suitable for custody transfer measurement

Output

Output signal

- 4 to 20 mA with superimposed digital communication protocol HART, 2-wire
- Digital communication signal PROFIBUS PA (Profile 3.0), 2-wire
 - Signal coding: Manchester Bus Powered (MBP): Manchester II
 - Transmission rate: 31.25 KBit/s voltage mode
- Digital communication signal FOUNDATION Fieldbus, 2-wire
 - Signal coding: Manchester Bus Powered (MBP): Manchester II
 - Transmission rate: 31.25 KBit/s voltage mode

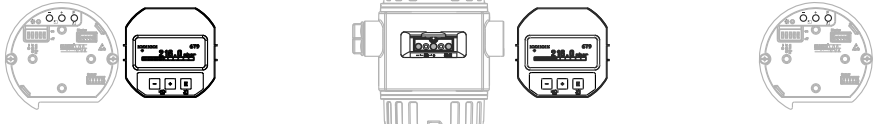
Output	Internal + LCD	External + LCD	Internal
			
	Option ¹⁾		
4 to 20mA HART	B	A	C
4 to 20mA HART, Li=0	E	D	F
PROFIBUS PA	N	M	O
FOUNDATION Fieldbus	Q	P	R

1) Product Configurator, order code for "Display, operation:"

Signal range 4 to 20 mA 3.8 mA to 20.5 mA

Signal on alarm As per NAMUR NE43

4 to 20 mA HART

- Max. alarm: Can be set between 21 to 23 mA (factory setting: 22 mA)
- Hold measured value: last measured value is held
- Min. alarm: 3.6 mA

PROFIBUS PA

Can be set in the Analog Input Block.

Options:

- Last Valid Out Value (factory setting)
- Fail Safe Value
- Status bad

FOUNDATION Fieldbus

Can be set in the Analog Input Block.

Options:

- Last Good Value
- Fail Safe Value (factory setting)
- Wrong Value

Maximum load - 4 to 20 mA HART

In order to guarantee sufficient terminal voltage in two-wire devices, a maximum load resistance R (including line resistance) must not be exceeded depending on the supply voltage U₀ of the supply unit. In the following load diagrams, observe the position of the jumper and the explosion protection:

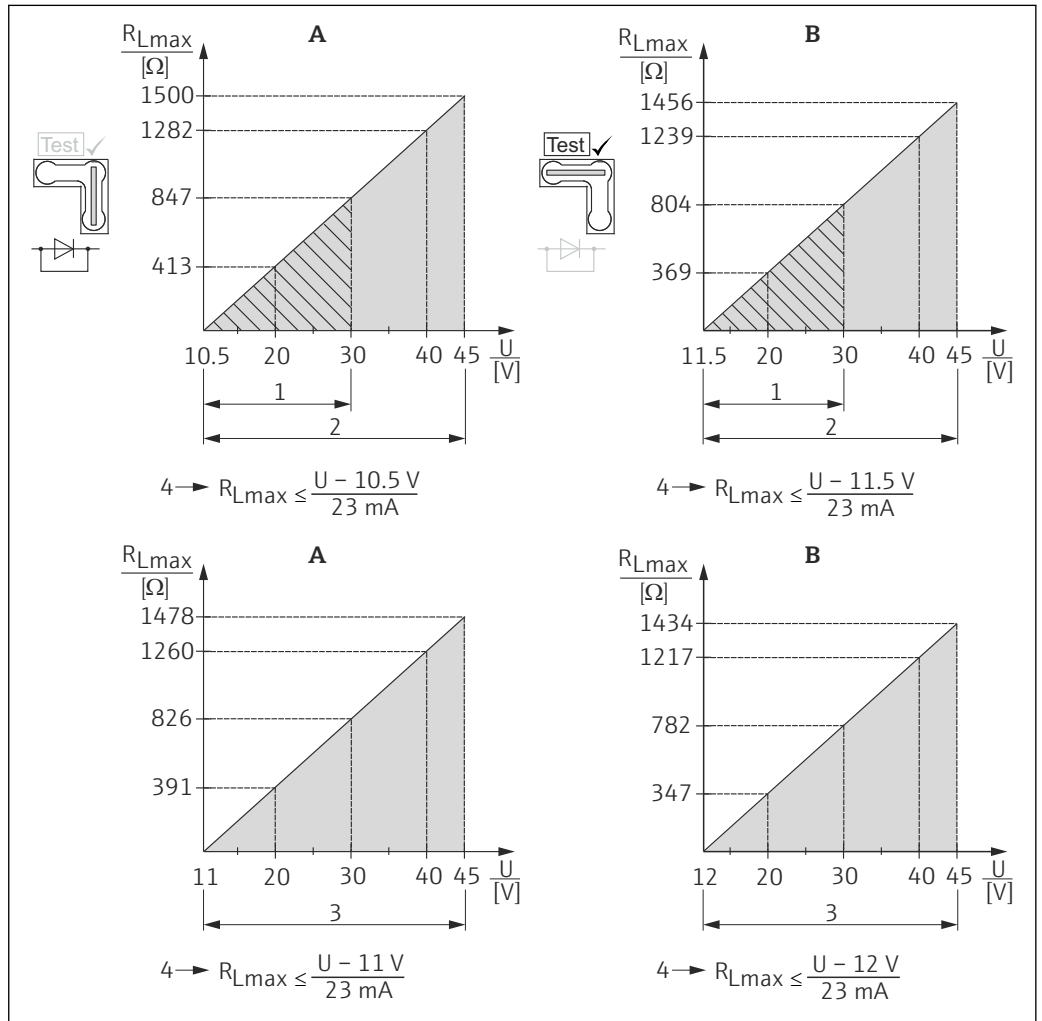

A0020467

- A Jumper for 4 to 20 mA test signal set to "Non-test" position
- B Jumper for 4 to 20 mA test signal set to "Test" position
- 1 Power supply 10.5 (11.5) to 30 V DC for 1/2 G, 1 GD, 1/2 GD, FM IS, CSA IS, IECEx ia, NEPSI Ex ia
- 2 Power supply 10.5 (11.5) to 45 V DC for devices for non-hazardous areas, 1/2 D, 1/3 D, 2 G Ex d, 3 G Ex nA, FM XP, FM DIP, FM NI, CSA XP, CSA dust ignition-proof, NEPSI Ex d
- 3 Power supply 11 (12) to 45 V DC for PMC71, Ex d[ia], NEPSI Ex d[ia]
- 4 R_{Lmax} maximum load resistance
- U Supply voltage



When operating via a handheld terminal or via a PC with an operating program, a minimum communication resistance of 250 Ω must be taken into account.

Dead time, time constant

Presentation of the dead time and the time constant:

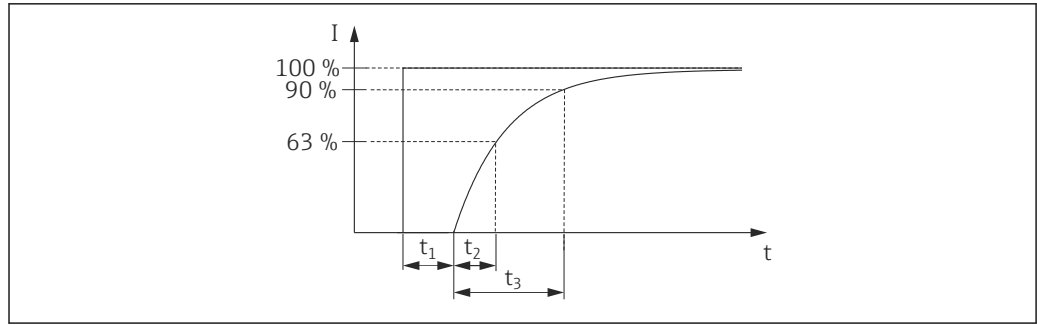

A0019786

**Dynamic behavior:
current output**

Type		Measuring cell	Dead time (t ₁) [ms]	Time constant T63 (t ₂) [ms]	Time constant T90 (t ₃) [ms]
PMC71	max.	All	90	120	276
PMP71	max.	<ul style="list-style-type: none"> ▪ 400 mbar (6 psi) ▪ ≥ 1 bar (15 psi) 	45	<ul style="list-style-type: none"> ▪ 70 ▪ 35 	<ul style="list-style-type: none"> ▪ 161 ▪ 81
PMP75	max.	PMP71 + influence of the diaphragm seal			

**Dynamic behavior: Digital
output (HART electronics)**

A typical burst rate of 300 ms results in the following behavior:

Type		Measuring cell	Dead time (t ₁) [ms]	Dead time (t ₁) [ms] + Time constant T63 (t ₂) [ms]	Dead time (t ₁) [ms] + Time constant T90 (t ₃) [ms]
PMC71	Min.	All	250	370	436
	max.		1050	1170	1236
PMP71	Min.	<ul style="list-style-type: none"> ▪ 400 mbar (6 psi) ▪ ≥ 1 bar (15 psi) 	205	<ul style="list-style-type: none"> ▪ 275 ▪ 240 	<ul style="list-style-type: none"> ▪ 321 ▪ 241
	max.	<ul style="list-style-type: none"> ▪ 400 mbar (6 psi) ▪ ≥ 1 bar (15 psi) 	1005	<ul style="list-style-type: none"> ▪ 1075 ▪ 1040 	<ul style="list-style-type: none"> ▪ 1121 ▪ 1041
PMP75	max.	PMP71 + influence of the diaphragm seal			

Reading cycle

- Acyclic: max. 3/s, typically 1/s (depending on command # and number of preambles)
- Cyclic (burst): max. 3/s, typically 2/s

The device commands the BURST MODE functionality for cyclical value transmission via the HART communication protocol.

Cycle time (update time)

Cyclic (burst): min. 300 ms

Response time

- Acyclic: min. 330 ms, typically 590 ms (depending on command # and number of preambles)
- Cyclic (burst): min. 160 ms, typically 350 ms (depending on command # and number of preambles)

**Dynamic behavior:
PROFIBUS PA**

A typical PLC cycle time of 1 s results in the following behavior:

Type		Measuring cell	Dead time (t ₁) [ms]	Dead time (t ₁) [ms] + Time constant T63 (t ₂) [ms]	Dead time (t ₁) [ms] + Time constant T90 (t ₃) [ms]
PMC71	Min.	All	125	245	311
	max.		1325	1445	1511

Type		Measuring cell	Dead time (t ₁) [ms]	Dead time (t ₁) [ms] + Time constant T63 (t ₂) [ms]	Dead time (t ₁) [ms] + Time constant T90 (t ₃) [ms]
PMP71	Min.	<ul style="list-style-type: none"> ▪ 400 mbar (6 psi) ▪ ≥ 1 bar (15 psi) 	80	<ul style="list-style-type: none"> ▪ 150 ▪ 115 	<ul style="list-style-type: none"> ▪ 196 ▪ 116
	max.	<ul style="list-style-type: none"> ▪ 400 mbar (6 psi) ▪ ≥ 1 bar (15 psi) 	1280	<ul style="list-style-type: none"> ▪ 1350 ▪ 1315 	<ul style="list-style-type: none"> ▪ 1396 ▪ 1316
PMP75	max.	PMP71 + influence of the diaphragm seal			

Reading cycle (PLC)

- Acyclic: Typically 25/s
- Cyclic: Typically 30/s (depending on the number and type of the function blocks used in the closed-control loop)

Cycle time (update time)

Min. 200 ms

The cycle time in a bus segment in cyclic data communication depends on the number of devices, on the segment coupler used and on the internal PLC cycle time. A new measured value can be determined up to five times a second.

Response time

- Acyclic: Approx. 60 ms to 70 ms (depending on Min. Slave Interval)
- Cyclic: Approx. 10 ms to 13 ms (depending on Min. Slave Interval)

Dynamic behavior: FOUNDATION Fieldbus

A typical configuration for the macro cycle time (host system) of 1 s results in the following behavior:

Type		Measuring cell	Dead time (t ₁) [ms]	Dead time (t ₁) [ms] + Time constant T63 (t ₂) [ms]	Dead time (t ₁) [ms] + Time constant T90 (t ₃) [ms]
PMC71	Min.	All	135	255	321
	max.		1135	1255	1321
PMP71	Min.	<ul style="list-style-type: none"> ▪ 400 mbar (6 psi) ▪ ≥ 1 bar (15 psi) 	90	<ul style="list-style-type: none"> ▪ 160 ▪ 125 	<ul style="list-style-type: none"> ▪ 206 ▪ 126
	max.	<ul style="list-style-type: none"> ▪ 400 mbar (6 psi) ▪ ≥ 1 bar (15 psi) 	1090	<ul style="list-style-type: none"> ▪ 1160 ▪ 1125 	<ul style="list-style-type: none"> ▪ 1206 ▪ 1126
PMP75	max.	PMP71 + influence of the diaphragm seal			

Reading cycle

- Acyclic: Typically 10/s
- Cyclic: max. 10/s (dependent on the number and type of function blocks used in a closed-control loop)

Cycle time (update time)

Cyclic: Min. 100 ms

Response time

- Acyclic: Typically 100 ms (for standard bus parameter settings)
- Cyclic: max. 20 ms (for standard bus parameter settings)

Damping

A damping affects all outputs (output signal, display):

- Via onsite display, handheld terminal or PC with operating program, continuous from 0 to 999 s
- Also for HART and PROFIBUS PA: Via DIP switch on the electronic insert, switch position "on" = set value and "off"
- Factory setting: 2 s

Alarm current	Description	Option ¹⁾
	Min alarm current	J
	HART burst mode PV	
	Min alarm current + HART burst mode PV	

1) Product Configurator, order code for "Additional options 1" and "Additional options 2"

Firmware version	Description	Option ¹⁾
	02.20.zz, HART, DevRev22	72
	02.11.zz, HART, DevRev21	73
	04.00.zz, FF, DevRev07	74
	04.01.zz, PROFIBUS PA, DevRev03	75
	02.10.zz, HART, DevRev21	76
	03.00.zz, FF, DevRev06	77
	04.00.zz, PROFIBUS PA	78

1) Product Configurator, order code for "Firmware version"

Protocol-specific data

HART

Manufacturer ID	17 (11 hex)
Device type code	24 (18 hex)
Device revision	<ul style="list-style-type: none"> ▪ 21 (15 hex) - SW version 02.1y.zz - HART specification 5 ▪ 22 (16 hex) - SW version 02.2y.zz - HART specification 7
HART specification	<ul style="list-style-type: none"> ▪ 5 ▪ 7
DD revision	<ul style="list-style-type: none"> ▪ 4 (Russian in language selection) for device revision 21 ▪ 3 (Dutch in language selection) for device revision 21 ▪ 1 for device revision 22
Device description files (DTM, DD)	Information and files at: <ul style="list-style-type: none"> ▪ www.endress.com ▪ www.hartcomm.org
HART load	Min. 250 Ω
HART device variables	The measured values are assigned to the device variables as follows: <p>Measured values for PV (primary variable)</p> <ul style="list-style-type: none"> ▪ Pressure ▪ Level ▪ Tank content <p>Measured values for SV, TV (second and third variable)</p> Pressure <p>Measured values for QV (fourth variable)</p> Temperature
Supported functions	<ul style="list-style-type: none"> ▪ Burst mode ▪ Additional transmitter status ▪ Device locking ▪ Alternative operating modes

PROFIBUS PA

Manufacturer ID	17 (11 hex)
Identification number	1541 hex

Profile version	<p>3.0</p> <ul style="list-style-type: none"> ▪ SW version 03.00.zz ▪ SW version 04.00.zz <p>3.02</p> <p>SW version 04.01.zz (device revision 3)</p> <p>Compatibility with SW version 03.00.zz and higher.</p>
GSD revision	<ul style="list-style-type: none"> ▪ 4 (SW version 3.00.zz and 4.00.zz) ▪ 5 (device revision 3)
DD revision	<ul style="list-style-type: none"> ▪ 1 (SW version 3.00.zz and 4.00.zz) ▪ 1 (device revision 3)
GSD file	Information and files at:
DD files	<ul style="list-style-type: none"> ▪ www.endress.com ▪ www.profibus.org
Output values	<p>Measured value for PV (via Analog Input Function Block)</p> <ul style="list-style-type: none"> ▪ Pressure ▪ Level ▪ ▪ Tank content <p>Measured value for SV</p> <ul style="list-style-type: none"> ▪ Pressure ▪ Temperature
Input values	Input value sent from PLC, can be shown on display
Supported functions	<ul style="list-style-type: none"> ▪ Identification & maintenance Simplest device identifier on the control system and nameplate ▪ Condensed status (only with Profile Version 3.02) ▪ Automatic ID number adjustment and switchable to the following ID numbers (only with Profile Version 3.02): <ul style="list-style-type: none"> - 9700: Profile-specific transmitter identification number with the "Classic" or "Condensed" status". - 1501: Compatibility mode for the old Cerabar S generation (PMC731, PMP731, PMC631, PMP635). - 1541: Identification number for the new Cerabar S generation (PMC71, PMP71, PMP75). ▪ Device locking: The device can be locked by hardware or software.

FOUNDATION Fieldbus

Manufacturer ID	452B48 hex
Device type	1007 hex
Device revision	<ul style="list-style-type: none"> ▪ 6 - SW version 03.00.zz ▪ 7 - SW version 04.00.zz (FF-912)
DD revision	<ul style="list-style-type: none"> ▪ 3 (device revision 6) ▪ 2 (device revision 7)
CFE revision	<ul style="list-style-type: none"> ▪ 4 (device revision 6) ▪ 1 (device revision 7)
DD files	Information and files at:
CFE files	<ul style="list-style-type: none"> ▪ www.endress.com ▪ www.fieldbus.org
Device tester version (ITK version)	<ul style="list-style-type: none"> ▪ 5.0 (device revision 6) ▪ 6.01 (device revision 7)
Number of ITK test campaign	<ul style="list-style-type: none"> ▪ IT054600 (Device Revision 6) ▪ IT085500 (Device Revision 7)
Link Master (LAS) capable	Yes
Choice of "Link Master" and "Basic Device"	Yes, factory setting is Basic Device
Node address	Factory setting: 247 (F7 hex)

Supported functions	Field diagnostics profile (only with FF912) The following methods are supported: <ul style="list-style-type: none"> ▪ Restart ▪ Configure error as warning or alarm ▪ HistoROM ▪ Peakhold ▪ Alarm info ▪ Sensor trim
Number of VCRs	<ul style="list-style-type: none"> ▪ 44 (device revision 6) ▪ 24 (device revision 7)
Number of link objects in VFD	50

Virtual communication references (VCRs)

	Device revision 6	Device revision 7
Permanent entries	44	1
Client VCRs	0	0
Server VCRs	5	10
Source VCRs	8	43
Sink VCRs	0	0
Subscriber VCRs	12	43
Publisher VCRs	19	43

Link settings

	Device revision 6	Device revision 7
Slot time	4	4
Min. Inter PDU delay	12	10
Max. response delay	10	10

Transducer Blocks

Block	Content	Output values
TRD1 Block	Contains all parameters related to the measurement	<ul style="list-style-type: none"> ▪ Pressure or level (channel 1) ▪ Process temperature (channel 2)
Service Block	Contains service information	<ul style="list-style-type: none"> ▪ Pressure after damping (channel 3) ▪ Pressure peakhold indicator (channel 4) ▪ Counter for max. pressure transgressions (channel 5)
Diagnostic Block	Contains diagnostic information	Error code via DI channels (channel 0 to 16)
Display Block	Contains parameters to configure the onsite display	No output values

Function blocks

Block	Content	Number blocks	Execution time		Functionality	
			Device Revision 6	Device Revision 7	Device Revision 6	Device Revision 7
Resource Block	This block contains all the data that uniquely identifies the device; it is an electronic version of a nameplate for the device.	1			enhanced	enhanced
Analog Input Block 1 Analog Input Block 2	The AI Block receives the measuring data from the Sensor Block, (selectable via a channel number) and makes the data available to other function blocks at its output. Enhancement: Digital outputs for process alarms, fail safe mode	2	45 ms	45 ms (without trend and alarm reports)	enhanced	enhanced
Digital Input Block	This block contains the discrete data of the Diagnose Block (selectable via a channel number 0 to 16) and provides them for other blocks at the output.	1	40 ms	30 ms	standard	enhanced
Digital Output Block	This block converts the discrete input and thus initiates an action (selectable via a channel number) in the DP Flow Block or in the Service Block. Channel 1 resets the counter for max. pressure transgressions.	1	60 ms	40 ms	standard	enhanced
PID Block	This block is used as a proportional-integral-derivative controller and can be used universally for closed-loop-control in the field. It enables cascade mode and feedforward control. Input IN can be indicated on the display. The selection is performed in the Display Block (DISPLAY_MAIN_LINE_CONTENT).	1	120 ms	70 ms	standard	enhanced
Arithmetic Block	This block is designed to permit simple use of popular measurement math functions. The user does not have to know how to write equations. The math algorithm is selected by name, chosen by the user for the function to be performed.	1	50 ms	40 ms	standard	enhanced
Input Selector Block	The Input Selector Block facilitates the selection of up to four inputs and generates an output based on the configured action. This block normally receives its inputs from AI Blocks. The block performs maximum, minimum, average and 'first good' signal selection. Inputs IN1 to IN4 can be indicated on the display. The selection is performed in the Display Block (DISPLAY_MAIN_LINE_CONTENT).	1	35 ms	35 ms	standard	enhanced
Signal Characterizer Block	The Signal Characterizer Block has two sections, each with an output that is a non-linear function of the respective input. The non-linear function is generated by a single look-up table with 21 arbitrary x-y pairs.	1	30 ms	40 ms	standard	enhanced
Integrator Block	The Integrator Block integrates a variable as a function of the time or accumulates the counts from a Pulse Input Block. The block can be used as a totalizer that counts up until a reset, or as a batch totalizer whereby the integrated value is compared against a target value generated before or during the control routine and generates a binary signal when the target value is reached.	1	35 ms	40 ms	standard	enhanced
Analog Alarm Block	This block contains all process alarm conditions (working like a comparator) and represents them at the output.	1	35 ms	35 ms	standard	enhanced

Additional function block information:

Instantiatable function blocks	YES	YES
Number of additional instantiatable function blocks	11	5

Power supply

⚠ WARNING

Electrical safety is compromised by an incorrect connection.

- ▶ When using the measuring device in hazardous areas, the relevant national standards and regulations as well as the Safety Instructions or Installation or Control Drawings must be observed → 112.
- ▶ All explosion protection data are given in separate documentation which is available upon request. The Ex documentation is supplied as standard with all Ex-systems → 112.
- ▶ Devices with integrated overvoltage protection must be grounded → 26.
- ▶ Protective circuits against reverse polarity, HF influences and overvoltage peaks are integrated.

Terminal assignment

4 to 20 mA HART

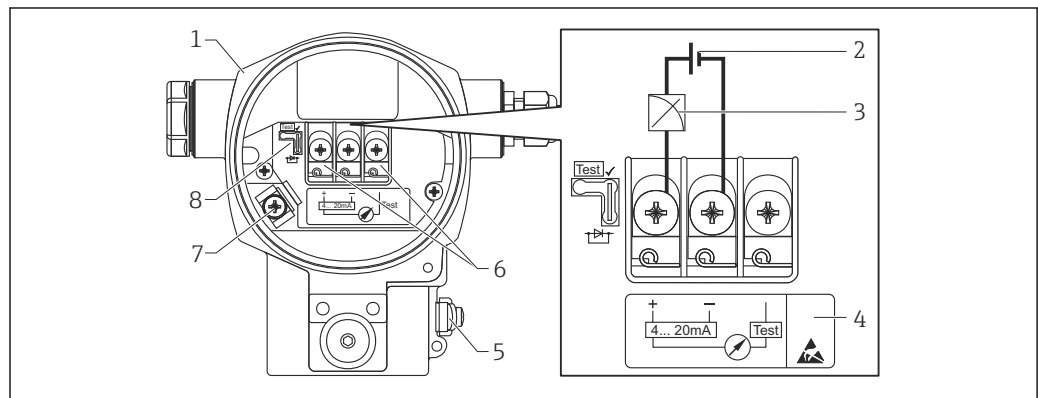

A0019989

- 1 Housing
- 2 Supply voltage
- 3 4 to 20 mA
- 4 Devices with integrated overvoltage protection are labeled "OVP" (overvoltage protection) here.
- 5 External ground terminal
- 6 4 to 20 mA test signal between positive and test terminal
- 7 Internal ground terminal
- 8 Jumper for 4 to 20 mA test signal

PROFIBUS PA and FOUNDATION Fieldbus

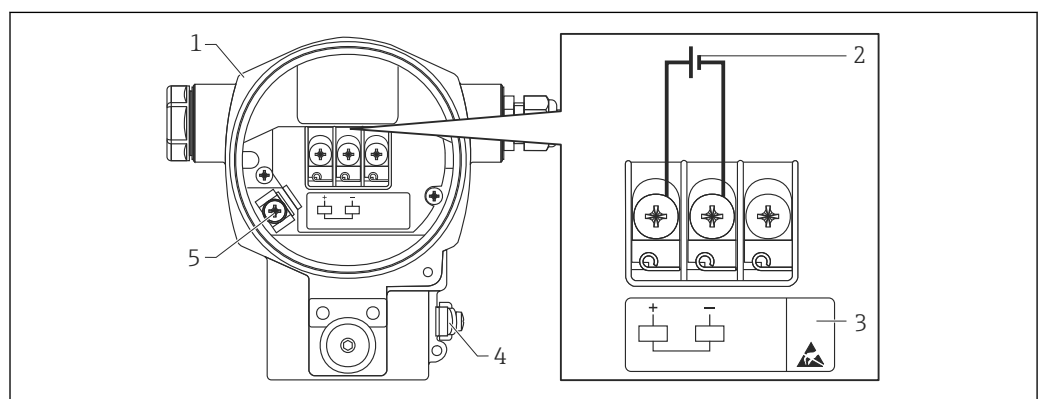

A0020158

- 1 Housing
- 2 Supply voltage
- 3 Devices with integrated overvoltage protection are labeled "OVP" (overvoltage protection) here.
- 4 External ground terminal
- 5 Internal ground terminal

Supply voltage

4 to 20 mA HART

Electronic version	Jumper for 4 to 20 mA test signal in "Test" position (delivery status)	Jumper for 4 to 20 mA test signal in "Non-test" position
Version for non-hazardous area	11.5 to 45 V DC	10.5 to 45 V DC
Intrinsically safe	11.5 to 30 V DC	10.5 to 30 V DC
<ul style="list-style-type: none"> ▪ Other types of protection ▪ Devices without certificate 	11.5 to 45 V DC (versions with 35 V DC plug-in connection)	10.5 to 45 V DC (versions with 35 V DC plug-in connection)

Measuring a 4 to 20 mA test signal

A 4 to 20 mA test signal may be measured via the positive and test terminal without interrupting the measurement. The minimum supply voltage of the device can be reduced by simply changing the position of the jumper. As a result, operation is also possible with lower voltage sources. Observe the position of the jumper in accordance with the following table.

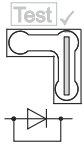
Jumper position for test signal	Description
 <p style="text-align: right; font-size: small;">A0019992</p>	<ul style="list-style-type: none"> ▪ Measurement of 4 to 20 mA test signal via the positive and test terminal: Possible. (Thus, the output current can be measured without interruption via the diode.) ▪ Delivery status ▪ Minimum supply voltage: 11.5 V DC
 <p style="text-align: right; font-size: small;">A0019993</p>	<ul style="list-style-type: none"> ▪ Measurement of 4 to 20 mA test signal via positive and test terminal: Not possible. ▪ Minimum supply voltage: 10.5 V DC

PROFIBUS PA

- Version for non-hazardous areas: 9 to 32 V DC
- Ex ia: 10.5 to 30 V DC

FOUNDATION Fieldbus

- Version for non-hazardous areas: 9 to 32 V DC
- Ex ia: 10.5 to 30 V DC

Current consumption

- PROFIBUS PA: 13 mA ±1 mA, switch-on current corresponds to IEC 61158-2, Clause 21
- FOUNDATION Fieldbus: 15.5 mA ±1 mA, switch-on current corresponds to IEC 61158-2, Clause 21

Electrical connection

PROFIBUS PA

The digital communication signal is transmitted to the bus via a 2-wire connection. The bus also provides the power supply. For further information on the network structure and grounding, and for further bus system components such as bus cables, see the relevant documentation, e.g. Operating Instructions BA00034S "PROFIBUS DP/PA: Guidelines for planning and commissioning" and the PNO Guideline.

FOUNDATION Fieldbus

The digital communication signal is transmitted to the bus via a 2-wire connection. The bus also provides the power supply. For further information on the network structure and grounding and for further bus system components such as bus cables, see the relevant documentation, e.g. Operating Instructions BA00013S "FOUNDATION Fieldbus Overview" and the FOUNDATION Fieldbus Guideline.

Terminals

- Supply voltage and internal ground terminal: 0.5 to 2.5 mm² (20 to 14 AWG)
- External ground terminal: 0.5 to 4 mm² (20 to 12 AWG)

Cable entries

Approval	Cable gland	Clamping area
Standard, II 1/2 G Ex ia, IS	Plastic M20x1.5	5 to 10 mm (0.2 to 0.39 in)
ATEX II 1/2 D, II 1/3 D, II 1/2 GD Ex ia, II 1 GD Ex ia, II 3 G Ex nA	Metal M20x1.5 (Ex e)	7 to 10.5 mm (0.28 to 0.41 in)

For additional technical data, see section on housing → 45

Connector

Devices with Harting plug Han7D

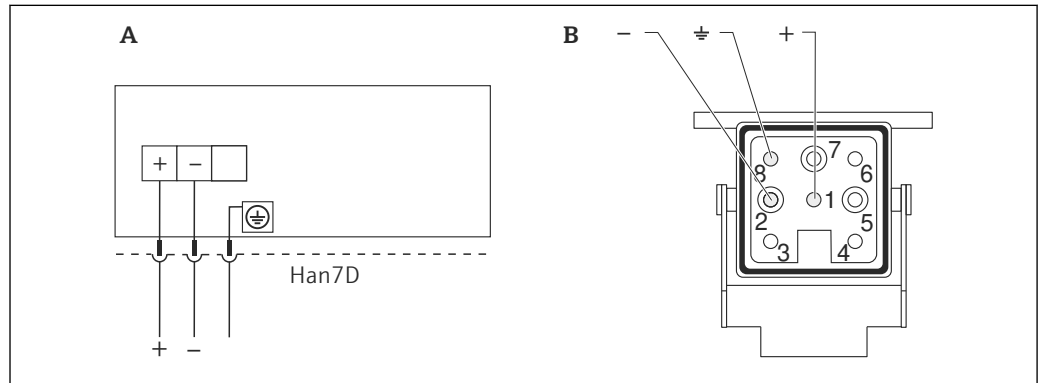

A Electrical connection for devices with Harting plug Han7D
 B View of the plug-in connection on the device

Material: CuZn, gold-plated plug-in jack and plug

Cable version connection

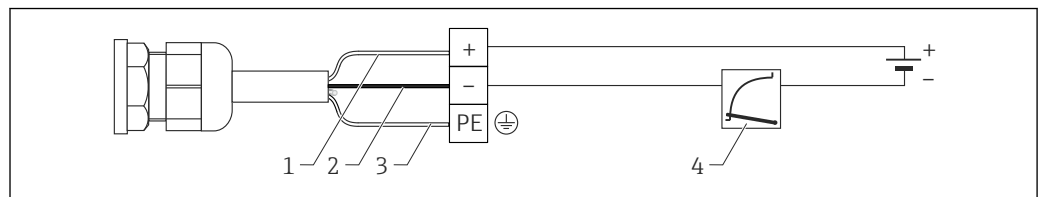

- 1 rd = red
- 2 bk = black
- 3 gnye = green
- 4 4 to 20 mA

Devices with M12 plug

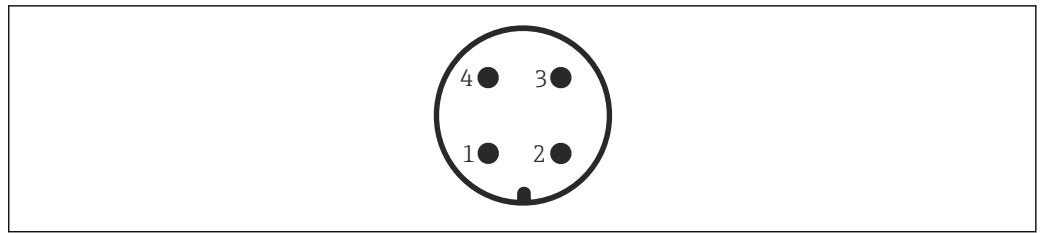

A0011175

- 1 *Signal +*
- 2 *Not assigned*
- 3 *Signal -*
- 4 *Ground*

Endress+Hauser offers the following accessories for devices with an M12 plug:

Plug-in jack M 12x1, straight

- Material: Body PA; coupling nut CuZn, nickel-plated
- Degree of protection (fully locked): IP67
- Order number: 52006263

Plug-in jack M 12x1, elbowed

- Material: Body PBT/PA; coupling nut GD-Zn, nickel-plated
- Degree of protection (fully locked): IP67
- Order number: 71114212

Cable 4x0.34 mm² (20 AWG) with M12 socket, elbowed, screw plug, length 5 m (16 ft)

- Material: Body PUR; coupling nut CuSn/Ni; cable PVC
- Degree of protection (fully locked): IP67
- Order number: 52010285

Devices with 7/8" plug

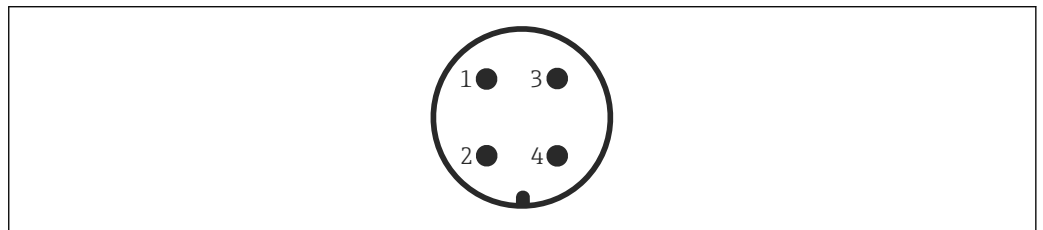

A0011176

- 1 *Signal -*
- 2 *Signal +*
- 3 *Not assigned*
- 4 *Shielding*

External thread: 7/8 - 16 UNC

- Material: 316L (1.4401)
- Degree of protection: IP68

Cable specification

HART

- Endress+Hauser recommends using shielded, twisted-pair two-wire cables.
- Cable outer diameter: 5 to 9 mm (0.2 to 0.35 in) depending on the cable entry used → 24

PROFIBUS PA

Use a twisted, shielded twin-core cable, preferably cable type A.

- For further information regarding cable specifications, see the Operating Instructions BA00034S "PROFIBUS DP/PA: Guidelines for planning and commissioning", the PNO guideline 2.092 "PROFIBUS PA User and Installation Guideline" and IEC 61158-2 (MBP).

FOUNDATION Fieldbus

Use a twisted, shielded twin-core cable, preferably cable type A.

 For further information on the cable specifications, see Operating Instructions BA00013S "FOUNDATION Fieldbus Overview", FOUNDATION Fieldbus Guideline and IEC 61158-2 (MBP).

Start-up current	12 mA
Residual ripple	Without influence on 4 to 20 mA signal up to $\pm 5\%$ residual ripple within the permitted voltage range [according to HART hardware specification HCF_SPEC-54 (DIN IEC 60381-1)].
Overvoltage protection (optional)	<ul style="list-style-type: none"> ▪ Overvoltage protection: <ul style="list-style-type: none"> - Nominal functioning DC voltage: 600 V - Nominal discharge current: 10 kA ▪ Surge current check $\hat{i} = 20$ kA satisfied as per DIN EN 60079-14: 8/20 μs ▪ Arrester AC current check $I = 10$ A satisfied <p>Ordering information: Product Configurator, order code for "Additional options 1" or "Additional options 2", version "M"</p> <p>NOTICE</p> <p>Device could be destroyed!</p> <ul style="list-style-type: none"> ▶ Devices with integrated overvoltage protection must be grounded.
Influence of power supply	≤ 0.0006 % of URL/1 V

Performance characteristics of ceramic process isolating diaphragm

Reference operating conditions	<ul style="list-style-type: none"> ■ As per IEC 60770 ■ Ambient temperature T_U = constant, in range: +21 to +33 °C (+70 to +91 °F) ■ Humidity ϕ = constant, in range: 5 to 80 % rH ■ Ambient pressure p_A = constant, in range: 860 to 1 060 mbar (12.47 to 15.37 psi) ■ Position of measuring cell = constant, in range: horizontal $\pm 1^\circ$ (see also "Influence of the installation position" section → ☰ 27) ■ Input of LOW SENSOR TRIM and HIGH SENSOR TRIM for lower range value and upper range value ■ Zero based span ■ Material of process isolating diaphragm: Al_2O_3 (aluminum-oxide ceramic, Ceraphire®) ■ Supply voltage: 24 V DC ± 3 V DC ■ Load with HART: 250 Ω
---------------------------------------	--

Measuring uncertainty for small absolute pressure measuring ranges	<p>The smallest expanded uncertainty of measurement that can be returned by our calibration standards is:</p> <ul style="list-style-type: none"> ■ in range 1 to 30 mbar (0.0145 to 0.435 psi): 0.4 % of reading ■ in range < 1 mbar (0.0145 psi): 1 % of reading.
---	---

Influence of the installation position	<p>≤ 0.18 mbar (0.003 psi). Device has rotated 180° and process connection is pointing upwards.</p> <p>A position-dependent zero point shift can be corrected → ☰ 34 and → ☰ 102.</p> <p>Different tightening torques (e.g. for Clamp or Varivent connections) can merely cause a shift in the zero point. This effect is corrected by position adjustment during commissioning.</p>
---	--

Resolution	<ul style="list-style-type: none"> ■ Current output: 1 μA ■ Display: can be set (factory setting: presentation of the maximum accuracy of the transmitter)
-------------------	--

Reference accuracy The reference accuracy contains the non-linearity [DIN EN 61298-2 3.11] including the pressure hysteresis [DIN EN 61298-23.13] and non-repeatability [DIN EN 61298-2 3.11] in accordance with the limit point method as per [DIN EN 60770].

Measuring cell standard	Sensor	Reference accuracy in %
100 mbar (1.5 psi)	Gauge pressure	<ul style="list-style-type: none"> ■ TD 1:1 to TD 10:1 = ± 0.075 ■ TD > 10:1 = $\pm 0.0075 \times TD$
100 mbar (1.5 psi)	Absolute pressure	<ul style="list-style-type: none"> ■ TD 1:1 to TD 5:1 = ± 0.075 ■ TD > 5:1 = $\pm 0.015 \times TD$
250 mbar (3.75 psi)	Gauge pressure/ Absolute pressure	<ul style="list-style-type: none"> ■ TD 1:1 to TD 10:1 = ± 0.075 ■ TD > 10:1 = $\pm 0.0075 \times TD$
400 mbar (6 psi), 1 bar (15 psi), 2 bar (30 psi), 4 bar (60 psi), 10 bar (150 psi), 40 bar (600 psi)	Gauge pressure/ Absolute pressure	<ul style="list-style-type: none"> ■ TD 1:1 to TD 10:1 = ± 0.05 ■ TD > 10:1 = $\pm 0.005 \times TD$

Platinum measuring cell	Sensor	Reference accuracy in %
100 mbar (1.5 psi), 250 mbar (3.75 psi)	Gauge pressure/ Absolute pressure	TD 1:1 = ± 0.05
400 mbar (6 psi), 1 bar (15 psi)	Gauge pressure/ Absolute pressure	TD 1:1 = ± 0.035
2 bar (30 psi), 4 bar (60 psi)	Gauge pressure	TD 1:1 = ± 0.025
2 bar (30 psi), 4 bar (60 psi)	Absolute pressure	TD 1:1 = ± 0.035
10 bar (150 psi), 40 bar (600 psi)	Gauge pressure/ Absolute pressure	TD 1:1 = ± 0.035

Thermal change of the zero output and the output span**Standard version**

Measuring cell	-10 to +60 °C (+14 to +140 °F)	-20 to -10 °C (-4 to +14 °F) +60 to +125 °C (+140 to +257 °F)
	% of the set span	
100 mbar (1.5 psi), 250 mbar (3.75 psi), 400 mbar (6 psi)	$\pm(0.088 \times \text{TD} + 0.088)$	$\pm(0.138 \times \text{TD} + 0.138)$
1 bar (15 psi), 2 bar (30 psi), 4 bar (60 psi), 10 bar (150 psi), 40 bar (600 psi)	$\pm(0.088 \times \text{TD} + 0.04)$	$\pm(0.175 \times \text{TD} + 0.075)$

High-temperature version

Measuring cell	Sensor	-10 to +60 °C (+14 to +140 °F)	+60 to +150 °C (140 to +302 °F)
		% of the set span	
100 mbar (1.5 psi), 250 mbar (3.75 psi), 400 mbar (6 psi)	Gauge pressure	$\pm(0.088 \times \text{TD} + 0.088)$	$\pm(0.75 \times \text{TD})$
1 bar (15 psi), 2 bar (30 psi), 4 bar (60 psi), 10 bar (150 psi), 40 bar (600 psi)	Gauge pressure	$\pm(0.088 \times \text{TD} + 0.040)$	$\pm(0.50 \times \text{TD})$
100 mbar (1.5 psi)	Absolute pressure	$\pm(0.088 \times \text{TD} + 0.088)$	$\pm(1.25 \times \text{TD})$
250 mbar (4 psi), 400 mbar (6 psi)	Absolute pressure	$\pm(0.088 \times \text{TD} + 0.088)$	$\pm(0.75 \times \text{TD})$
1 bar (15 psi), 2 bar (30 psi), 4 bar (60 psi), 10 bar (150 psi)	Absolute pressure	$\pm(0.088 \times \text{TD} + 0.040)$	$\pm(0.75 \times \text{TD})$
40 bar (600 psi)	Absolute pressure	$\pm(0.088 \times \text{TD} + 0.040)$	$\pm(0.50 \times \text{TD})$

Total performance

The "Total performance" specification comprises the non-linearity including hysteresis and non-reproducibility as well as the thermal change of the zero point. For devices with NBR or HNBR seals, the values must be multiplied by a factor of 3. All specifications apply to the temperature range -10 to +60 °C (+14 to +140 °F) and a turndown of 1:1.

Measuring cell	Standard version	High-temperature version
	% of URL	
100 mbar (1.5 psi), 250 mbar (3.75 psi), 400 mbar (6 psi)	± 0.2	± 0.46
1 bar (15 psi), 2 bar (30 psi), 4 bar (60 psi), 10 bar (150 psi), 40 bar (600 psi)	± 0.15	± 0.46

Long-term stability

- For measuring ranges ≥ 1 bar (15 psi) ± 0.05 % of URL/year
- 100 mbar (1.5 psi) to 40 bar (600 psi): ± 0.2 % of URL/10 years
- 100 mbar (1.5 psi) to 40 bar (600 psi) (absolute pressure sensor): ± 0.3 % of URL/10 years

Total error

The total error comprises the total performance and long-term stability. For devices with NBR or HNBR seals, the values must be multiplied by a factor of 3. All specifications apply to the temperature range -10 to +60 °C (+14 to +140 °F) and a turndown of 1:1.

Measuring cell	Standard version	High-temperature version
	% of URL/year	
100 mbar (1.5 psi), 250 mbar (3.75 psi), 400 mbar (6 psi)	±0.25	±0.51
1 bar (15 psi), 2 bar (30 psi), 4 bar (60 psi), 10 bar (150 psi), 40 bar (600 psi)	±0.2	±0.51

Warm-up period

- 4 to 20 mA HART: < 10 s
- PROFIBUS PA: 6 s
- FOUNDATION Fieldbus: 50 s

Performance characteristics of the metallic process isolating diaphragm

Reference operating conditions

- As per IEC 60770
- Ambient temperature T_U = constant, in range: +21 to +33 °C (+70 to +91 °F)
- Humidity φ = constant, in range: 5 to 80 % rH
- Ambient pressure p_A = constant, in range: 860 to 1060 mbar (12.47 to 15.37 psi)
- Position of measuring cell = constant, in range: horizontal $\pm 1^\circ$ (see also "Influence of the installation position" section → [30](#))
- Input of LOW SENSOR TRIM and HIGH SENSOR TRIM for lower range value and upper range value
- Zero based span
- Material of the process isolating diaphragm: AISI 316L (1.4435)
- Filling oil: silicone oil
- Supply voltage: 24 V DC ± 3 V DC
- Load with HART: 250 Ω

Measuring uncertainty for small absolute pressure measuring ranges

The smallest expanded uncertainty of measurement that can be returned by our calibration standards is:

- in range 1 to 30 mbar (0.0145 to 0.435 psi): 0.4 % of reading
- in range < 1 mbar (0.0145 psi): 1 % of reading.

Influence of the installation position

PMP71: Device rotated 180°, process connection pointing upwards.
 – Process connections thread G 1 A, G 1 ½, G 2, 1 ½ MNPT, 2 MNPT, M 44x1,25, EN/DIN, ASME and JIS flanges: ≤ 10 mbar (0.15 psi).
 – Process connections thread: G ½, ½ MNPT, JIS G ½, JIS R ½, M20x1.5: ≤ 4 mbar (0.06 psi).

The value is doubled for devices with inert oil.



A position-dependent zero point shift can be corrected → [34](#) and → [102](#).

Different tightening torques (e.g. for Clamp or Varivent connections) can merely cause a shift in the zero point. This effect is corrected by position adjustment during commissioning.

Resolution

- Current output: 1 μ A
- Display: can be set (factory setting: presentation of the maximum accuracy of the transmitter)

Reference accuracy

The reference accuracy contains the non-linearity [DIN EN 61298-2 3.11] including the pressure hysteresis [DIN EN 61298-23.13] and non-repeatability [DIN EN 61298-2 3.11] in accordance with the limit point method as per [DIN EN 60770]. The specifications refer to the calibrated span.

PMP71

Measuring cell standard	Sensor	Reference accuracy in %
400 mbar (6 psi)	Gauge pressure/ Absolute pressure	<ul style="list-style-type: none"> ■ TD 1:1 = ± 0.05 ■ TD > 1:1 = $\pm 0.05 \times \text{TD}$
1 bar (15 psi)	Gauge pressure/ Absolute pressure	<ul style="list-style-type: none"> ■ TD 1:1 to TD 2.5:1 = ± 0.05 ■ TD > 2.5:1 = $\pm 0.02 \times \text{TD}$
2 bar (30 psi)	Gauge pressure	<ul style="list-style-type: none"> ■ TD 1:1 to TD 5:1 = ± 0.05 ■ TD > 5:1 = $\pm 0.01 \times \text{TD}$
2 bar (30 psi)	Absolute pressure	<ul style="list-style-type: none"> ■ TD 1:1 to TD 5:1 = ± 0.05 ■ TD > 5:1 = $\pm 0.01 \times \text{TD}$
4 bar (60 psi), 10 bar (150 psi)	Gauge pressure/ Absolute pressure	<ul style="list-style-type: none"> ■ TD 1:1 to TD 10:1 = ± 0.05 ■ TD > 10:1 = $\pm 0.005 \times \text{TD}$
40 bar (600 psi)	Gauge pressure/ Absolute pressure	<ul style="list-style-type: none"> ■ TD 1:1 to TD 15:1 = ± 0.075 ■ TD > 15:1 = $\pm 0.005 \times \text{TD}$
100 bar (1 500 psi)	Gauge pressure/ Absolute pressure	<ul style="list-style-type: none"> ■ TD 1:1 to TD 10:1 = ± 0.075 ■ TD > 10:1 = $\pm 0.0075 \times \text{TD}$

Measuring cell standard	Sensor	Reference accuracy in %
400 bar (6 000 psi)	Gauge pressure/ Absolute pressure	<ul style="list-style-type: none"> ■ TD 1:1 to TD 5:1 = ±0.15 ■ TD > 5:1 = ±0.03 x TD
700 bar (10 500 psi)	Absolute pressure	<ul style="list-style-type: none"> ■ TD 1:1 to TD 5:1 = ±0.15 ■ TD > 5:1 = ±0.03 x TD

Platinum measuring cell ¹⁾	Sensor	Reference accuracy in %
400 mbar (6 psi), 1 bar (15 psi)	Gauge pressure/ Absolute pressure	TD 1:1 = ±0.035
2 bar (30 psi), 4 bar (60 psi), 10 bar (150 psi)	Gauge pressure	TD 1:1 = ±0.025
2 bar (30 psi), 4 bar (60 psi), 10 bar (150 psi)	Absolute pressure	TD 1:1 = ±0.035
40 bar (600 psi)	Gauge pressure/ Absolute pressure	TD 1:1 = ±0.05
100 bar (1 500 psi)	Absolute pressure	TD 1:1 = ±0.05
400 bar (6 000 psi), 700 bar (10 500 psi)	Gauge pressure/ Absolute pressure	TD 1:1 = ±0.075

1) Platinum version not for flush-mounted process connections G ½ and M20.

Ordering information

Description	Option ¹⁾
Platinum	"K" or "L" or "M"

1) Product Configurator, order code for "Calibration; unit"

PMP75

Measuring cell standard	Sensor	PMP75 without capillary in %	PMP75 with capillary in %
400 mbar (6 psi)	Gauge pressure/ Absolute pressure	<ul style="list-style-type: none"> ■ TD 1:1 = ±0.15 ■ TD > 1:1 = ±0.15 x TD 	<ul style="list-style-type: none"> ■ TD 1:1 = ±0.15 ■ TD > 1:1 = ±0.15 x TD
1 bar (15 psi)	Gauge pressure/ Absolute pressure	<ul style="list-style-type: none"> ■ TD 1:1 to TD 2.5:1 = ±0.075 ■ TD > 2.5:1 = ±0.03 x TD 	<ul style="list-style-type: none"> ■ TD 1:1 to TD 2.5:1 = ±0.1 ■ TD > 2.5:1 = ±0.04 x TD
2 bar (30 psi)	Gauge pressure	<ul style="list-style-type: none"> ■ TD 1:1 to TD 5:1 = ±0.075 ■ TD > 5:1 = ±0.015 x TD 	<ul style="list-style-type: none"> ■ TD 1:1 to TD 2.5:1 = ±0.1 ■ TD > 2.5:1 = ±0.04 x TD
2 bar (30 psi)	Absolute pressure	<ul style="list-style-type: none"> ■ TD 1:1 to TD 5:1 = ±0.075 ■ TD > 5:1 = ±0.015 x TD 	<ul style="list-style-type: none"> ■ TD 1:1 to TD 5:1 = ±0.075 ■ TD > 5:1 = ±0.015 x TD
4 bar (60 psi)	Gauge pressure/ Absolute pressure	<ul style="list-style-type: none"> ■ TD 1:1 to TD 10:1 = ±0.075 ■ TD > 10:1 = ±0.0075 x TD 	<ul style="list-style-type: none"> ■ TD 1:1 to TD 10:1 = ±0.075 ■ TD > 10:1 = ±0.0075 x TD
10 bar (150 psi), 40 bar (600 psi)	Gauge pressure/ Absolute pressure	<ul style="list-style-type: none"> ■ TD 1:1 to TD 15:1 = ±0.075 ■ TD > 15:1 = ±0.005 x TD 	<ul style="list-style-type: none"> ■ TD 1:1 to TD 15:1 = ±0.075 ■ TD > 15:1 = ±0.005 x TD
100 bar (1 500 psi)	Gauge pressure/ Absolute pressure	<ul style="list-style-type: none"> ■ TD 1:1 to TD 10:1 = ±0.075 ■ TD > 10:1 = ±0.0075 x TD 	<ul style="list-style-type: none"> ■ TD 1:1 to TD 10:1 = ±0.075 ■ TD > 10:1 = ±0.0075 x TD
400 bar (6 000 psi)	Gauge pressure/ Absolute pressure	<ul style="list-style-type: none"> ■ TD 1:1 to TD 5:1 = ±0.15 ■ TD > 5:1 = ±0.03 x TD 	<ul style="list-style-type: none"> ■ TD 1:1 to TD 5:1 = ±0.15 ■ TD > 5:1 = ±0.03 x TD
700 bar (10 500 psi)	Absolute pressure	<ul style="list-style-type: none"> ■ TD 1:1 to TD 5:1 = ±0.15 ■ TD > 5:1 = ±0.03 x TD 	—

Platinum measuring cell ¹⁾	Sensor	PMP75 without capillary in %		PMP75 without capillary in %
1 bar (15 psi), 2 bar (30 psi), 4 bar (60 psi), 10 bar (150 psi), 40 bar (600 psi), 400 bar (6 000 psi), 700 bar (10 500 psi)	Gauge pressure/ Absolute pressure	TD 1:1	= ±0.05	—

1) Platinum version not for flush-mounted process connections G ½ and M20.

Thermal change of the zero output and the output span

 When using a PMP75, the influence of the respective diaphragm seal must also be taken into account →  99.

PMP71 and PMP75 (basic device), internal process isolating diaphragm

Measuring cell	Material of the Process isolating diaphragm		-10 to +60 °C (+14 to +140 °F)	-40 to -10 °C (-40 to +14 °F) +60 to +80 °C (+140 to +176 °F)
	316 L	Gold/ rhodium	% of the set span	
400 mbar (6 psi)	✓	✓	±(0.2 x TD + 0.015)	±(0.4 x TD + 0.03)
1 bar (15 psi), 2 bar (30 psi), 4 bar (60 psi), 10 bar (150 psi)	✓	✓	±(0.1 x TD + 0.01)	±(0.4 x TD + 0.02)
40 bar (600 psi)	✓	—	±(0.1 x TD + 0.01)	±(0.4 x TD + 0.02)
100 bar (1 500 psi)	✓	—	±(0.2 x TD + 0.015)	±(0.4 x TD + 0.03)
400 bar (6 000 psi)	✓	—	±(0.35 x TD + 0.02)	±(0.7 x TD + 0.04)
700 bar (10 500 psi)	✓	—	±(0.4 x TD + 0.03)	±(0.7 x TD + 0.04)

PMP71, flush-mounted process isolating diaphragm made of 316L with gold-rhodium coating

Measuring cell	-10 to +60 °C (+14 to +140 °F)	-40 to -10 °C (-40 to +14 °F) +60 to +80 °C (+140 to +176 °F)
	% of the set span	
400 mbar (6 psi)	±(0.2 x TD + 0.015) x 5	±(0.4 x TD + 0.03) x 5
1 bar (15 psi), 2 bar (30 psi), 4 bar (60 psi), 10 bar (150 psi), 40 bar (600 psi)	±(0.1 x TD + 0.01) x 5	±(0.4 x TD + 0.02) x 5
100 bar (1 500 psi)	±(0.2 x TD + 0.015) x 5	±(0.4 x TD + 0.03) x 5
400 bar (6 000 psi)	±(0.35 x TD + 0.02) x 5	±(0.7 x TD + 0.04) x 5
700 bar (10 500 psi)	±(0.4 x TD + 0.03) x 5	±(0.7 x TD + 0.04) x 5

Total performance

The "Total performance" specification comprises the non-linearity including hysteresis and non-reproducibility as well as the thermal change of the zero point.

All specifications apply to the temperature range -10 to +60 °C (+14 to +140 °F) and a turndown of 1:1.

PMP71

Measuring cell	PMP71	PMP71 with gold-rhodium coated Process isolating diaphragm
	% of URL	
400 mbar (6 psi)	±0.25	±1.25
1 bar (15 psi)	±0.15	±0.75
2 bar (30 psi)	±0.15	±0.45
4 bar (60 psi)	±0.15	±0.3
10 bar (150 psi), 40 bar (600 psi)	±0.15	±0.15
100 bar (1 500 psi)	±0.25	±0.25
400 bar (6 000 psi)	±0.3	±0.3
700 bar (10 500 psi)	±0.3	±0.3

Long-term stability

	Measuring cell	1 year	5 years	10 years
		% of URL		
PMP71	400 mbar (6 psi)	±0.05	±0.07	±0.10
	1 bar (15 psi)	±0.05	±0.07	±0.10
	2 bar (30 psi)	±0.07	±0.12	±0.15
	4 bar (60 psi), 10 bar (150 psi), 40 bar (600 psi), 100 bar (1 500 psi), 400 bar (6 000 psi), 700 bar (10 500 psi)	±0.05	±0.07	±0.10
PMP75	To determine long-term stability, the basic device is observed without the attached diaphragm seal.			

Total error

PMP71

The total error comprises the total performance and long-term stability. All specifications apply to the temperature range -10 to +60 °C (+14 to +140 °F) and a turndown of 1:1.



Measuring cell	% of URL/year
400 mbar (6 psi)	±0.3
1 bar (15 psi), 2 bar (30 psi), 4 bar (60 psi), 10 bar (150 psi), 40 bar (600 psi)	±0.2
100 bar (1 500 psi)	±0.3
400 bar (6 000 psi)	±0.35
700 bar (10 500 psi)	±0.35

Warm-up period

- 4 to 20 mA HART: < 10 s
- PROFIBUS PA: 6 s
- FOUNDATION Fieldbus: 50 s

Installation

General installation instructions

- For PMP75: →  99 "Installation instructions" section.
- A position-dependent zero point shift can be corrected directly at the device via operating keys, and also in hazardous areas in the case of devices with external operation. Diaphragm seals also shift the zero point, depending on the installation position →  102.
- The device housing can be rotated up to 380°.
- Endress+Hauser offers a mounting bracket for installing the device on pipes or walls →  34.
- Use flushing rings for flange and cell diaphragm seals if buildup or clogging can be expected at the diaphragm seal connection. The flushing ring can be fitted between the process connection and diaphragm seal. Material buildup in front of the process isolating diaphragm can be flushed away, and the pressure chamber vented, via the two lateral flushing holes.
- When measuring in media containing solids, such as dirty liquids, installing separators and drain valves is useful for capturing and removing sediment.
- Point the cable and connector downwards where possible to prevent moisture from entering (e.g. rain or condensation water).

Measuring arrangement for devices without diaphragm seals – PMC71, PMP71

Cerabar S transmitters without diaphragm seals are mounted as per the norms for a manometer (DIN EN 837-2). We recommend the use of shutoff devices and siphons. The orientation depends on the measuring application.

Pressure measurement in gases

Mount Cerabar S with shutoff device above the tapping point so that any condensate can flow into the process.

Pressure measurement in vapors

Use siphons for pressure measurement in steam. The siphon reduces the temperature to almost ambient temperature. Fill the siphon with liquid before commissioning. Preferably mount the Cerabar S with the siphon below the tapping point.

Advantages:

- defined water column only causes minimal/negligible measured errors
- only minimal/negligible thermal effects on the device

Mounting above the tapping point is also possible. Note the max. permitted ambient temperature of the transmitter.

Pressure measurement in liquids

Mount Cerabar S with shutoff device below or at the same level as the tapping point.



Level measurement

- Mount Cerabar S below the lowest measuring point.
- Do not install the device in the following positions: In the filling curtain, in the tank outlet or at a point in the container which could be affected by pressure pulses from an agitator or a pump.
- The calibration and functional test can be carried out more easily if you mount the device downstream from a shutoff device.

Measuring arrangement for devices with diaphragm seals – PMP75

→  99

Orientation

The orientation may cause a zero point shift, see →  27 and →  30.

This position-dependent zero point shift can be corrected directly at the device via the operating key, and also in hazardous areas in the case of devices with external operation (position adjustment).

Wall and pipe mounting

Endress+Hauser offers a mounting bracket for installing the device on pipes or walls. The mounting bracket can be installed on pipes with a diameter of 1¼" to 2" or on walls.

Ordering information:

- Product Configurator, order code for "Additional options 2", version "U" or Product Configurator, order code for "Accessory enclosed", version "PA" or
- as a separate accessory (part no.: 71102216).

Dimensions → 86.

Heat insulation – PMC71 high-temperature version

The PMC71 high-temperature version must only be insulated up to a certain height. The maximum permitted insulation height is indicated on the devices and applies to an insulation material with a heat conductivity $\leq 0.04 \text{ W/(m x K)}$ and to the maximum permitted ambient and process temperature (see table below). The data were determined under the most critical application "quiescent air".

The data were determined under the most critical application "quiescent air".

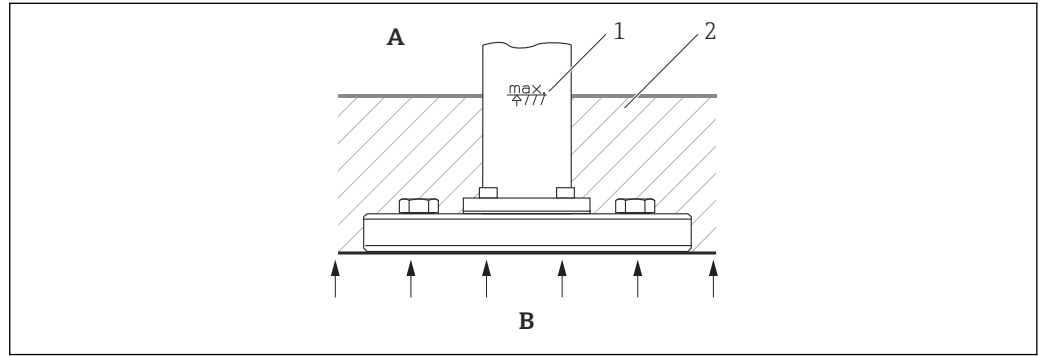

- A Ambient temperature
- B Process temperature
- 1 Insulation height
- 2 Insulation material

	Temperature
Ambient temperature	$\leq 70 \text{ °C (158 °F)}$
Process temperature	$\leq 150 \text{ °C (302 °F)}$

Mounting of PVDF screw-in fittings



Risk of damage to process connection!

Risk of injury!

- ▶ PVDF process connections with threaded connections must be installed with the mounting bracket supplied.

The mounting bracket can be installed on pipes with a diameter of 1¼" to 2" or on walls.

- The mounting bracket is included in the delivery.
- Ordering information:
Product Configurator, order code for "Accessory enclosed", version "PA" or as a separate accessory (part no.: 71102216).
- Dimensions .

"Separate housing" version

With the "separate housing" version, you are able to mount the housing with the electronics insert at a distance from the measuring point. This version facilitates trouble-free measurement:

- Under particularly difficult measuring conditions (at installation locations that are cramped or difficult to access)
- If rapid cleaning of the measuring point is required and
- If the measuring point is exposed to vibrations
- For compact installations

You can choose between different cable versions:

- PE: 2 m (6.6 ft), 5 m (16 ft) and 10 m (33 ft)
- FEP: 5 m (16 ft).

Ordering information: Product Configurator, order code for "Additional options 2", version "G".

Dimensions →  86

In the case of the "separate housing" version, the sensor is delivered with the process connection and cable ready mounted. The housing and a mounting bracket are enclosed as separate units. The cable is provided with a socket at both ends. These sockets are simply connected to the housing and the sensor.

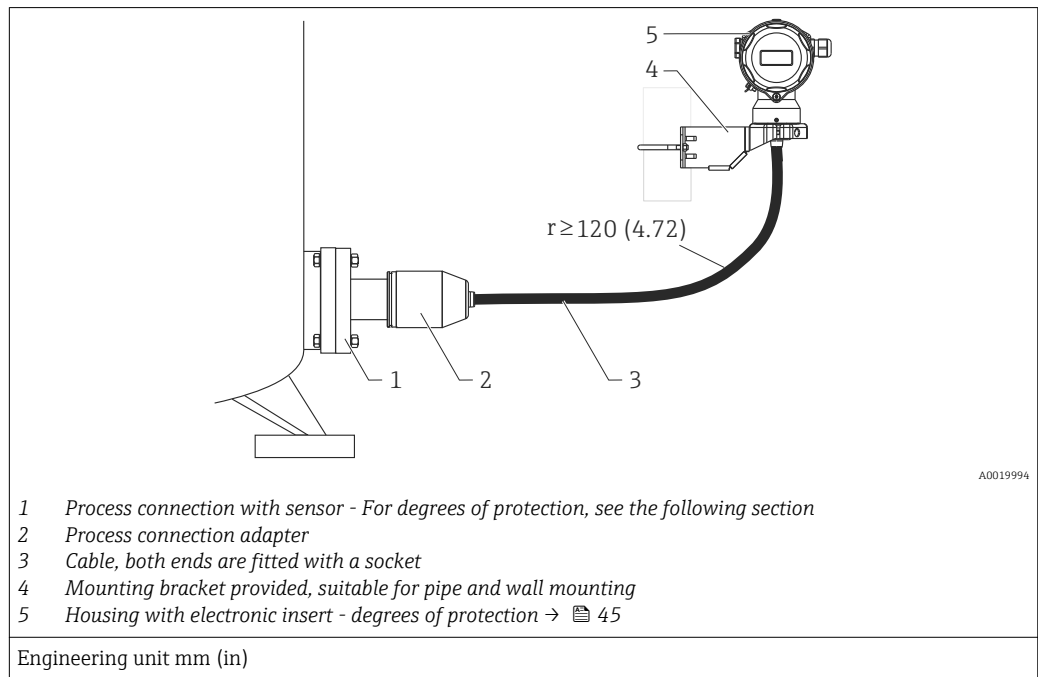

Degree of protection for the process connection and sensor with the use of

- FEP cable:
 - IP 69
 - IP 66 NEMA 4/6P
 - IP 68 (1.83 mH₂O for 24 h) NEMA 4/6P
- PE cable:
 - IP 66 NEMA 4/6P
 - IP 68 (1.83 mH₂O for 24 h) NEMA 4/6P

Technical data of the PE and FEP cable:

- Minimum bending radius: 120 mm (4.72 in)
- Cable extraction force: max. 450 N (101.16 lbf)
- Resistance to UV light

Use in hazardous area:

- Intrinsically safe installations (Ex ia/IS)
- FM/CSA IS: for Div. 1 installation only

Description	Weight
Process connection adapter	0.93 kg (2.05 lb)
Cable	0.05 kg/meter (0.11 lb)

Reduction of the installation height

If the separate housing is used, the installation height of the process connection is reduced compared to the dimensions of the standard version.

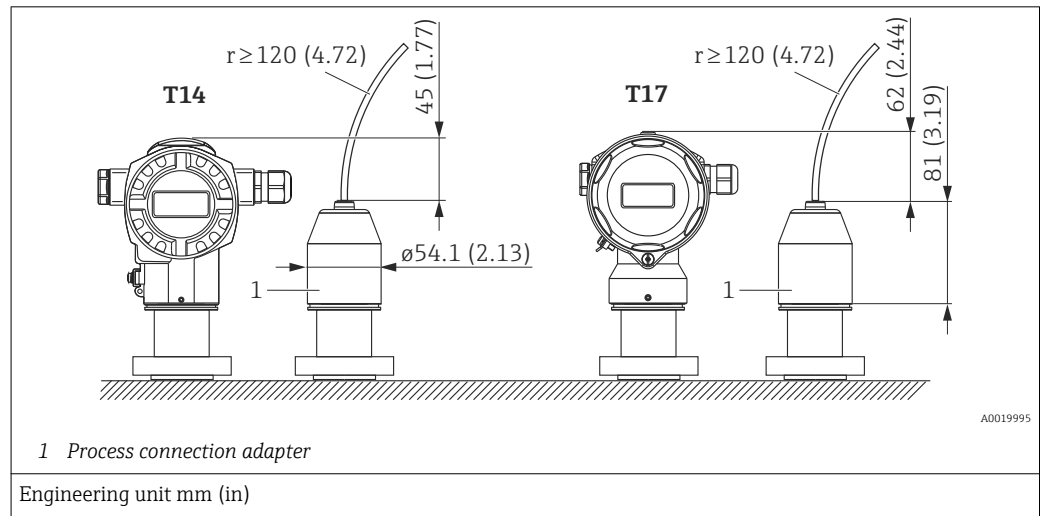

Turning the housing

The housing can be rotated up to 380° by loosening the Allen screw.

Your benefits

- Easy mounting due to optimum alignment of housing
- Good, accessible device operation
- Optimum readability of the onsite display (optional).

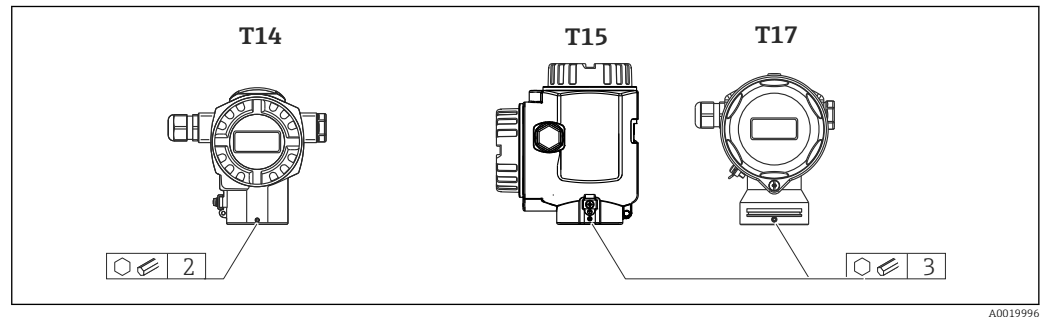

Oxygen applications

Oxygen and other gases can react explosively to oils, grease and plastics, such that, among other things, the following precautions must be taken:

- All components of the system, such as measuring devices, must be cleaned in accordance with the BAM (DIN 19247) requirements.
- Dependent on the materials used, a certain maximum temperature and a maximum pressure for oxygen applications must not be exceeded.

The devices suitable for gaseous oxygen applications are listed in the following table with the specification p_{\max} .

Order code for devices ¹⁾ , cleaned for oxygen applications	p_{\max} for oxygen applications	T_{\max} for oxygen applications
PMC71 – * * * * * 2 * *, Devices with sensors, nominal value < 10 bar (150 psi)	Over pressure limit (OPL) ^{2) 3)} of sensor	60 °C (140 °F)
PMC71 – * * * * * 2 * *, Devices with sensors, nominal value ≥ 10 bar (150 psi)	30 bar (450 psi)	60 °C (140 °F)
PMP71 – * * * * * N * *	depends on the lowest-rated element, with regard to pressure, of the selected components: over pressure limit (OPL) of the sensor, process connection (1.5 x PN) or fill fluid (160 bar (2 400 psi))	85 °C (185 °F)
PMP75 – * * * * * N * *	depends on the lowest-rated element, with regard to pressure, of the selected components: over pressure limit (OPL) of the sensor, process connection (1.5 x PN) or fill fluid (160 bar (2 400 psi))	85 °C (185 °F)

1) Devices only, not accessories or enclosed accessories.

2) Product Configurator, order code for "Sensor range; sensor over pressure limit (= OPL)"

3) PMC71 with PVDF thread or flange: To be mounted only with mounting bracket. MWP 10 bar (150 psi), OPL max. 15 bar (225 psi). Process temperature range -10 to +60 °C (+14 to +140 °F)

Silicone-free applications

Special cleaning of the transmitter to remove paint-wetting substances, for use in paint shops for example.

Ordering information:

Product Configurator, order code for "Seal", option "L" or "M".

Ultrapure gas applications

Endress+Hauser also offers devices for special applications, such as ultrapure gas, cleaned from oil and grease. No special restrictions regarding the process conditions apply to these devices.

Ordering information:

- Product Configurator, order code for "Seal" or
- Product Configurator, order code for "Fill fluid".

Applications with hydrogen**Liquid applications with hydrogen separation from an electrolyte**

The gold-rhodium coating, which can be ordered in the order code, offers protection only against hydrogen diffusion through the process isolating diaphragm in liquids (e.g. electrolytes or aqueous solutions).

Ordering information:

Product Configurator, order code for "Membrane material", option "6".

In gas applications and also in liquid applications with hydrogen separation from an electrolyte with a process temperature >100 °C (212 °F), the gold-rhodium coating does **not** offer effective protection against hydrogen diffusion through the process isolating diaphragm. The diaphragm requires a pure gold coating. Endress+Hauser offers this product version with a gold coating of 25 µm (984.3 µin) as a **Technical Special Product**.

Gas applications with hydrogen content

In the case of a gas application with hydrogen content, the diaphragm requires a pure gold coating. Endress+Hauser offers this product version with a gold coating of 25 µm (984.3 µin) as a **Technical Special Product**.

Environment

Ambient temperature range	Version	PMC71 High-temperature version	PMC71	PMP71 ¹⁾	PMP75 ¹⁾
	Without LCD display	-20 to +70 °C (-4 to +158 °F)	-40 to +85 °C (-40 to +185 °F)		
	With LCD display ²⁾		-20 to +70 °C (-4 to +158 °F)		
	With M12 connector, elbowed		-25 to +85 °C (-13 to +185 °F)		
	With separate housing	—	-20 to +60 °C (-4 to +140 °F)		—
	Diaphragm seal systems ³⁾	—	—	—	→ 99
	MID parts certificate	—	—	-25 to +55 °C (-13 to +131 °F)	—

- 1) Lower temperatures on request
- 2) Extended temperature application range (-40 to +85 °C (-40 to +185 °F)) with restrictions in optical properties, such as display speed and contrast
- 3) Ambient temperature range and process temperature range are mutually dependent - see "Heat insulation" section → 103

For high-temperature applications, either a PMP75 with a temperature isolator or with a capillary can be used. If vibrations also occur in the application, Endress+Hauser recommends using a PMP75 with a capillary. If a PMP75 with a temperature isolator or capillary is used, we recommend a suitable bracket for mounting (see "Wall and pipe mounting" section) → 34.

Hazardous areas

- For devices for use in hazardous areas, see Safety Instructions, Installation or Control Drawing → 112.
- Pressure measuring devices that have the usual explosion protection certificates (e.g. ATEX/ FM/ CSA/ IEC Ex,...) can be used in hazardous areas at ambient temperatures down to -50 °C (-58 °F). The functionality of the explosion protection is also guaranteed for ambient temperatures down to -50 °C (-58 °F).
- The nameplate specification is limited to an ambient temperature of -40 °C (-40 °F), as all measurement-specific testing of the device is performed only down to -40 °C (-40 °F). If the device is operated at an ambient temperature below -40 °C (-40 °F), the technical data in this document are no longer valid. Functional restrictions can be expected.

Storage temperature range	<ul style="list-style-type: none"> ■ -40 to +90 °C (-40 to +194 °F) ■ Local display: -40 to +85 °C (-40 to +185 °F) ■ Separate housing -40 to +60 °C (-40 to +140 °F) ■ Devices with PVC-sheathed capillary: -25 to +90 °C (-13 to +194 °F)
Degree of protection	<ul style="list-style-type: none"> ■ Housing → 45 ■ Separate housing → 36
Climate class	Class 4K4H (air temperature: -20 to +55 °C (-4 to +131 °F), relative humidity: 4 to 100 %) fulfilled as per DIN EN 60721-3-4 (condensation possible. With PMC71, avoid condensate in the device.)
Electromagnetic compatibility	<ul style="list-style-type: none"> ■ Electromagnetic compatibility as per EN 61326 and NAMUR recommendation EMC (NE21). ■ With enhanced immunity against electromagnetic fields as per EN 61000-4-3: 30 V/m with closed cover (for devices with T14 housing) ■ Maximum deviation: < 0.5 % of span ■ All EMC measurements were performed with a turn down (TD) = 2:1. ■ Class E3 as per OIML R75-2

For further details refer to the Declaration of Conformity. A description of how to download this document is provided in the next section.

Downloading the Declaration of Conformity

<http://www.endress.com/en/download>

Endress+Hauser Download Area
 Search and download operating manuals, brochures, publications, software updates, videos, certificates and a whole host of other documents!
 To narrow your search results appropriately, please choose 'Media Type' first.

1 — Product Code (e.g. FTL260, 83F, 50H) Advanced
Reset

2 — Text Search

Media Type 3

4 —

A0027319-EN

1. Enter the required product code
2. Select "Approvals & Certificates"
3. Select "Manufact. Declaration"
4. Click on "Start Search"

The available downloads are displayed.

Vibration resistance

Device/accessory	Test standard	Vibration resistance
PMC71 ¹⁾	GL	Guaranteed for 3 to 25 Hz: ±1.6 mm (0.063 in); 25 to 100 Hz: 4 g in all 3 planes
PMP71		
PMP75 ^{2) 3)}		
With mounting bracket	IEC 61298-3	Guaranteed for 10 to 60 Hz: ±0.15 mm (0.0059 in); 60 to 500 Hz: 2 g in all 3 planes
PMP71 with MID parts certificate	OIML R117-1	Class M3

- 1) Not for high-temperature version with Ex d[ia], CSA XP or FM XP
- 2) With aluminum T14 housing only
- 3) For applications with very high temperatures, a PMP75 with either a temperature isolator or a capillary can be used. If vibrations also occur in the application, Endress+Hauser recommends using a PMP75 with a capillary. If a PMP75 with a temperature isolator or capillary is used, it must be mounted with a mounting bracket

Process

Process temperature limits For oxygen applications → 38

PMC71 (with ceramic process isolating diaphragm)

- -25 to +125 °C (-13 to +257 °F)
- High-temperature version: -20 to +150 °C (-4 to +302 °F); Product Configurator, order code for "Additional options 1", version "T".
- For saturated steam applications, use a device with a metal process isolating diaphragm, or provide a siphon for temperature isolation when installing.
- Observe the process temperature range of the seal in the following table.

Seal	Notes	Process temperature range	Option ¹⁾
FKM Viton	–	-25 to +125 °C (-13 to +257 °F)/ 150 °C (302 °F) ²⁾	A, L
EPDM	FDA 21CFR177.2600; 3A Class II; USP Class VI DVGW (KTW, W270, W534), WRAS, ACS, NSF61	-20 to +125 °C (-4 to +257 °F)/ 150 °C (302 °F) ²⁾	B
EPDM	–	-20 to +150 °C (-4 to +302 °F)	B
Kalrez, Compound 4079	–	+5 to +125 °C (+41 to +257 °F)/ 150 °C (302 °F) ²⁾	D, M
Chemraz, Compound 505	–	-10 to +125 °C (+14 to +257 °F)/ 150 °C (302 °F) ²⁾	E
HNBR	FDA 21CFR177.2600; 3A Class II; KTW; AFNOR; BAM	-25 to +125 °C (-13 to +257 °F)	F ³⁾
NBR	–	-10 to +100 °C (+14 to +212 °F)	F
FKM Viton	FDA 21CFR177.2600	-5 to +125 °C (+23 to +257 °F)	G
FKM Viton	cleaned of oil and grease	-10 to +125 °C (+14 to +257 °F)/ 150 °C (302 °F) ²⁾	1
FKM Viton	cleaned for oxygen service	-10 to +60 °C (+14 to +140 °F)	2

The process temperature ranges specified here refer to permanent application of the PMC71. They may be exceeded for a short time (e.g. for cleaning).

- 1) Product Configurator, order code for "Seal"
- 2) 150 °C (302 °F) for high-temperature version
- 3) These seals are used for devices with 3A-approved process connections.

Applications with jumps in temperature

Extreme jumps in temperature can result in temporary measuring errors. Temperature compensation takes effect after several minutes. Internal temperature compensation is faster the smaller the jump in temperature and the longer the time interval involved. For further information please contact your local Endress+Hauser Sales Center.

PMP71 (with metallic process isolating diaphragm)

Description	Limits
Process connections with internal process isolating diaphragm	-40 to +125 °C (-40 to +257 °F) (150 °C (302 °F) for max. one hour)
Process connections with flush-mounted process isolating diaphragm, G 1 A, G 1 ½ A, G 2 A, 1 NPT, 1 ½ NPT, 2 NPT, M 44x1.25, EN/DIN, ASME and JIS flanges	-40 to +100 °C (-40 to +212 °F)
Process connections with flush-mounted process isolating diaphragm, G ½ A, M20x1.5	-20 to +85 °C (-4 to +185 °F)

PMP71 (with metallic process isolating diaphragm) with MID parts certificate

-25 to +55 °C (-13 to +131 °F)

PMP75 (with diaphragm seal)

- Depending on the design and depending on the diaphragm seal and filling oil: -70 °C (-94 °F) up to +400 °C (+752 °F). Please note the temperature application limits of the diaphragm seal oil → 101.
- Please observe the maximum gauge pressure and maximum temperature.

Devices with PTFE-coated process isolating diaphragm

The non-stick coating has excellent gliding properties and is used to protect the process isolating diaphragm against abrasive media.

NOTICE

Incorrect use of the PTFE foil will destroy the device!

- ▶ The PTFE foil used is designed to protect the unit against abrasion. It does not provide protection against corrosive media.

For the range of application of the 0.25 mm (0.01 in) PTFE foil on an AISI 316L (1.4404/1.4435) process isolating diaphragm, see the following diagram:

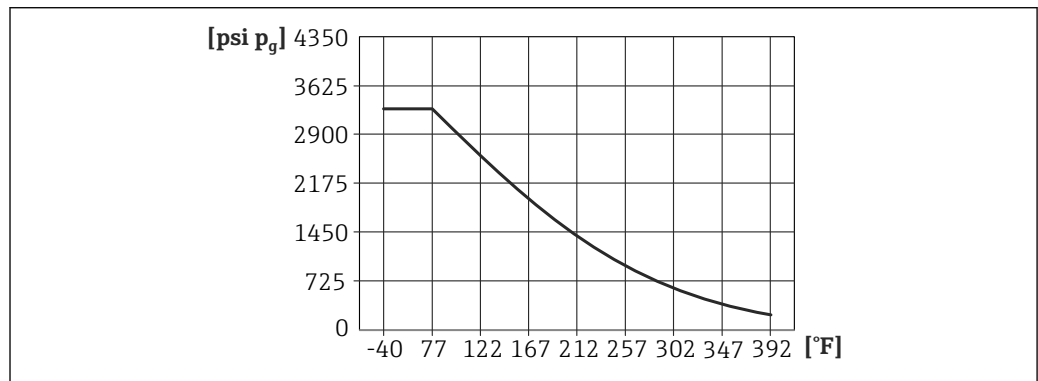

A0026949-EN

- i** For vacuum applications: $p_{abs} \leq 1 \text{ bar (14.5 psi)}$ to 0.05 bar (0.725 psi) up to max. +150 °C (302 °F).

Process temperature limits of flexible capillary armoring: PMP75

- 316L: No restrictions
- PTFE: No restrictions
- PVC: See the following diagram

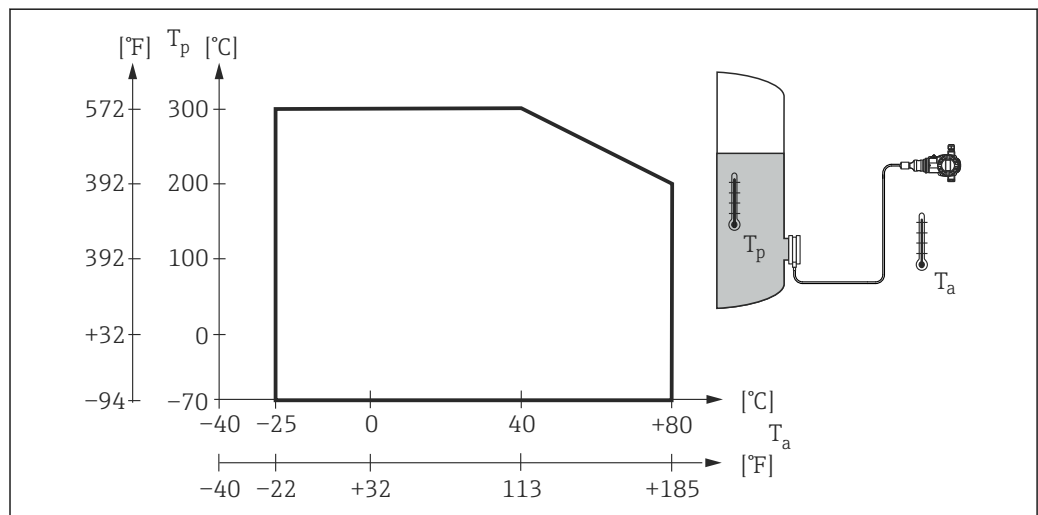

A0028220

Pressure specifications

⚠ WARNING

The maximum pressure for the measuring device depends on the lowest-rated element with regard to pressure.

- ▶ For pressure specifications, see the "Measuring range" section and the "Mechanical construction" section.
- ▶ The measuring device must be operated only within the specified limits!
- ▶ The MWP (maximum working pressure) is specified on the nameplate of the individual sensor module. This value refers to a reference temperature of +20 °C (+68 °F), or +38 °C (+100 °F) for ASME flanges, and can be present at the device for an unlimited period. Observe the pressure-temperature dependency of the MWP.
- ▶ Please refer to the standards EN 1092-1: 2001 Tab. 18 for the pressure values permitted in the case of higher temperatures. (With regard to their stability-temperature property, the materials 1.4435 and 1.4404 are grouped together under 13E0 in EN 1092-1 Tab. 18. The chemical composition of the two materials can be identical). // ASME B 16.5a – 1998 Tab. 2-2.2 F316 // ASME B 16.5a – 1998 Tab. 2.3.8 N10276 // JIS B 2220
- ▶ The test pressure corresponds to the over pressure limit of the individual sensors (OPL = 1.5 x MWP (formula does not apply to the PMP71 or PMP75 with a 40 bar (600 psi) or 100 bar (1500 psi) measuring cell)) and may be applied only for a limited period of time to prevent any lasting damage.
- ▶ The Pressure Equipment Directive (EC Directive 97/23/EC) uses the abbreviation "PS". The abbreviation "PS" corresponds to the MWP (maximum working pressure) of the measuring device.
- ▶ In the case of sensor range and process connections where the over pressure limit (OPL) of the process connection is smaller than the nominal value of the sensor, the device is set at the factory, at the very maximum, to the OPL value of the process connection. If you want to use the entire sensor range, select a process connection with a higher OPL value (1.5 x PN; MWP = PN)
- ▶ In oxygen applications, the values for p_{\max} and T_{\max} for oxygen applications must not be exceeded → 38.
- ▶ Steam hammering must be avoided. Steam hammering can cause zero point drifts. Recommendation: Residue (water droplets or condensation) may remain on the process isolating diaphragm following CIP cleaning and can result in local steam hammering the next time steam cleaning takes place. In practice, drying the process isolating diaphragm (e.g. by blowing) has proved to prevent steam hammering.

Mechanical construction

Device height

The device height is calculated from

- the height of the housing
- the height of optional mounted parts such as temperature isolators or capillaries
- the height of the relevant process connection.

The individual heights of the components can be found in the following sections. To calculate the device height, simply add up the individual heights of the components. If necessary, the installation space (the space used to install the device) must also be taken into account. You can use the following table for this:

Section	Page	Height	Example
Height of housing	→ 45 ff.	(A)	
Optional mounted parts	→ 49	(B)	
Process connections	→ 49	(H)	
Installation space	-	(I)	
Device height			

T14 housing, optional display on the side

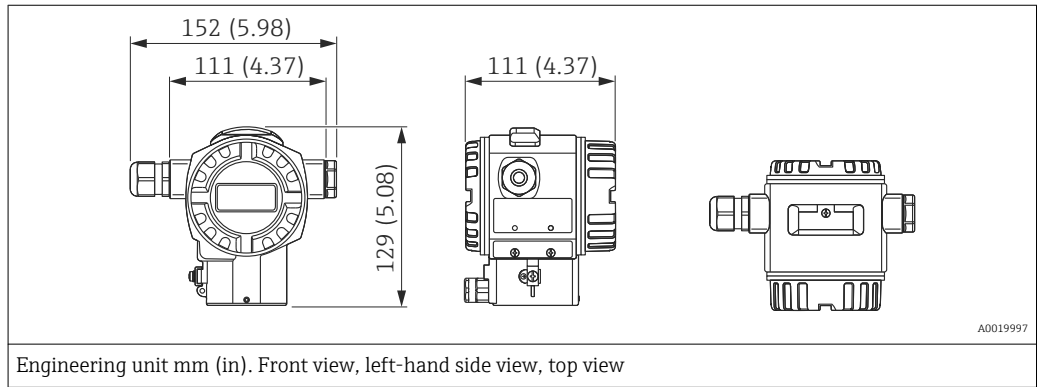

Material		Degree of protection	Cable entry	Weight in kg (lb)		Option ¹⁾
Housing	Cover seal			with display	without display	
Aluminum	EPDM	IP66/67 NEMA 6P	M20 gland	1.2 (2.65)	1.1 (2.43)	A
		IP66/67 NEMA 6P	G ½" thread			B
		IP66/67 NEMA 6P	NPT ½" thread			C
		IP66/67 NEMA 6P	M12 plug			D
		IP66/67 NEMA 6P	7/8" plug			E
		IP65 NEMA 4	HAN7D plug 90 degrees			F
316L	EPDM	IP66/67 NEMA 6P	M20 gland	2.1 (4.63)	2.0 (4.41)	1
		IP66/67 NEMA 6P	G ½" thread			2
		IP66/67 NEMA 6P	NPT ½" thread			3
		IP66/67 NEMA 6P	M12 plug			4
		IP66/67 NEMA 6P	7/8" plug			5
		IP65 NEMA 4	HAN7D plug 90 degrees			6
	FVMQ	IP66/67 NEMA 6P	M20 gland	7		
	FVMQ	IP66/67 NEMA 6P	NPT ½" thread	8		

1) Product Configurator, order code for "Housing, cover seal, cable entry, degree of protection"

T17 housing (hygienic), optional display on the side

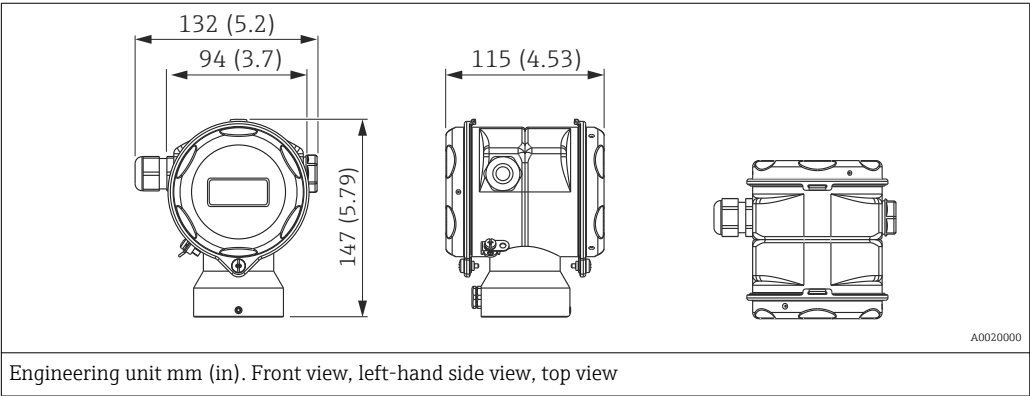

Material		Degree of protection ¹⁾	Cable entry	Weight in kg (lb)		Option ²⁾
Housing	Cover seal			with display	without display	
316L	EPDM	IP66/68 NEMA 6P	M20 gland	1.2 (2.65)	1.1 (2.43)	R
		IP66/68 NEMA 6P	G ½" thread			S
		IP66/68 NEMA 6P	NPT ½" thread			T
		IP66/68 NEMA 6P	M12 plug			U
		IP66/68 NEMA 6P	7/8" plug			V

1) Degree of protection IP 68: 1.83 mH₂O for 24 h
 2) Product Configurator, order code for "Housing, cover seal, cable entry, degree of protection"

Process connections for
PMC71 with internal process
isolating diaphragm

Threaded connection ISO 228 G

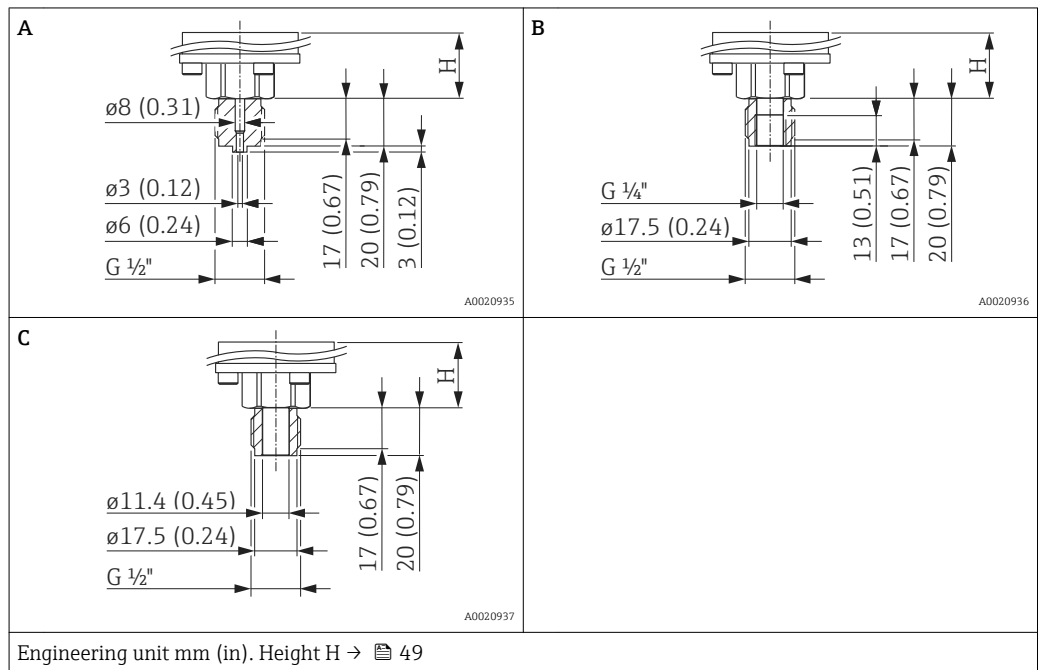

Item	Description	Material	Weight	Approval ¹⁾	Option ²⁾
			kg (lb)		
A	Thread ISO 228 G 1/2" A EN 837	AISI 316L	0.63 (1.39)	CRN	GA
		Alloy C276 (2.4819)		CRN	GB
		Monel (2.4360)		-	GC
		PVDF <ul style="list-style-type: none"> ■ Only mount with a mounting bracket (included) ■ MWP 10 bar (150 psi), OPL max. 15 bar (225 psi) ■ Process temperature range: +10 to +60 °C (+14 to +140 °F) 		-	GD
B	Thread ISO 228 G 1/2" A, G 1/4" (internal)	AISI 316L	CRN	GE	
		Alloy C276 (2.4819)	CRN	GF	
		Monel (2.4360)	-	GG	
C	Thread ISO 228 G 1/2" A, Hole 11.4 mm (0.45 in)	AISI 316L	CRN	GH	
		Alloy C276 (2.4819)	CRN	GJ	
		Monel (2.4360)	-	GK	

- 1) CSA approval: Product Configurator, order code for "Approval"
- 2) Product Configurator, order code for "Process connection"

Threaded connection ANSI

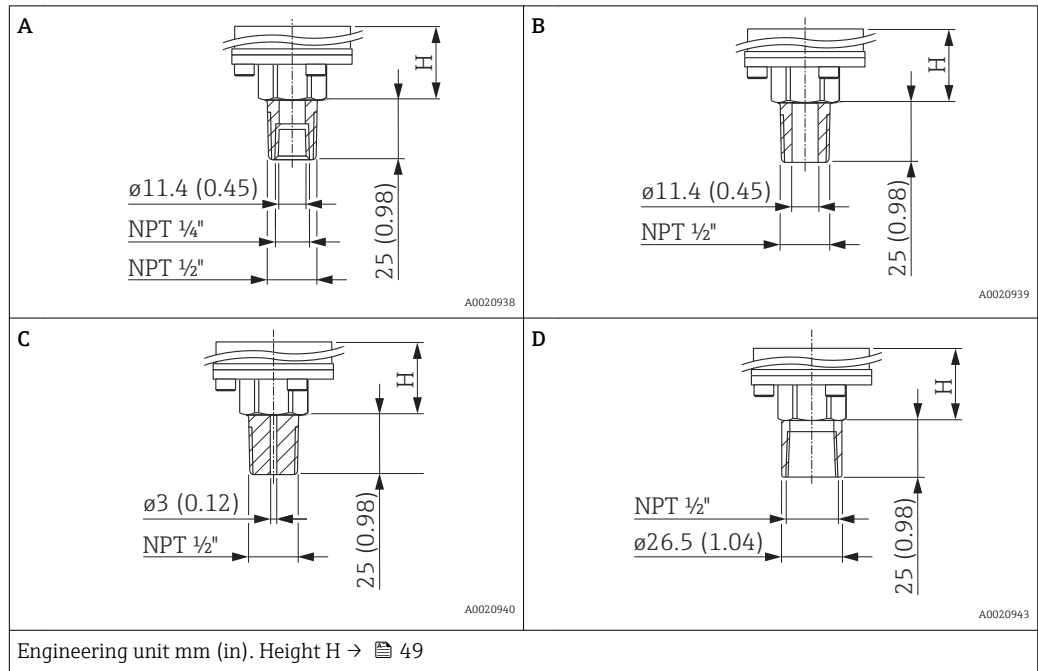

Item	Description	Material	Weight	Approval ¹⁾	Option ²⁾
			kg (lb)		
A	ANSI 1/2" MNPT, 1/4" FNPT	AISI 316L	0.63 (1.39)	CRN	RA
		Alloy C276 (2.4819)		CRN	RB
		Monel (2.4360)		-	RC
B	ANSI 1/2" MNPT, Hole 11.4 mm (0.45 in)	AISI 316L		CRN	RD
		Alloy C276 (2.4819)		CRN	RE
		Monel (2.4360)		-	RF
C	ANSI 1/2" MNPT, Hole 3 mm (0.12 in)	PVDF <ul style="list-style-type: none"> ■ Only mount with a mounting bracket (included) ■ MWP 10 bar (150 psi), OPL max. 15 bar (225 psi) ■ Process temperature range: +10 to +60 °C (+14 to +140 °F) 		-	RG
D	ANSI 1/2" FNPT Hole 11.4 mm (0.45 in)	AISI 316L		CRN	RH
		Alloy C276 (2.4819)	CRN	RJ	
		Monel (2.4360)	-	RK	

1) CSA approval: Product Configurator, order code for "Approval"

2) Product Configurator, order code for "Process connection"

Process connections for
PMC71 with internal process
isolating diaphragm

Threaded connection JIS

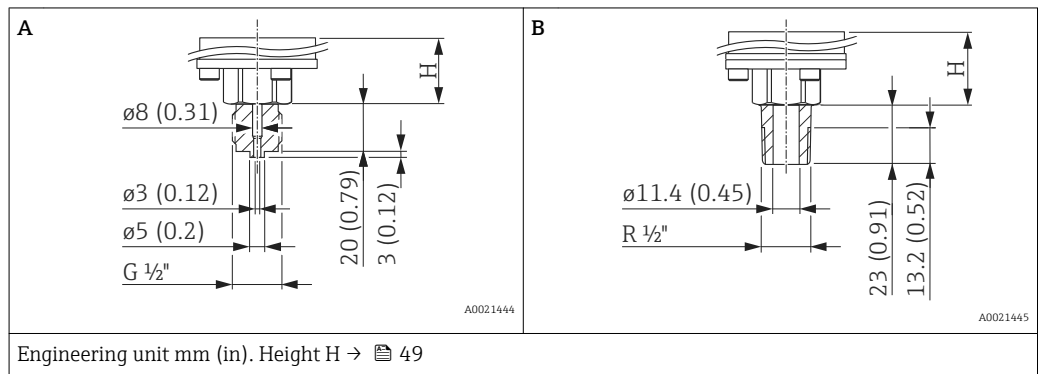

Item	Description	Material	Weight	Option ¹⁾
			kg (lb)	
A	JIS B0202 G 1/2" (male)	AISI 316L	0.63 (1.39)	GL
B	JIS B0203 R 1/2" (male)			RL

1) Product Configurator, order code for "Process connection"

Threaded connection DIN 13

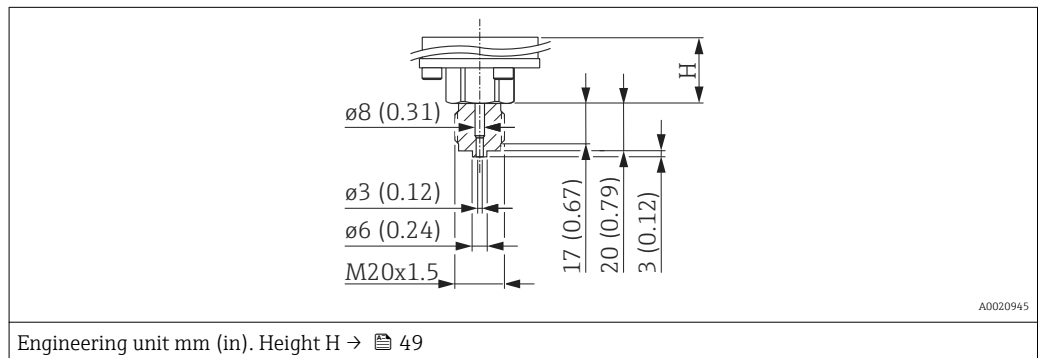

Description	Material	Weight	Option ¹⁾
		kg (lb)	
DIN 13 M20 x 1.5, EN 837 3 mm (0.12 in)	AISI 316L	0.63 (1.39)	GP
	Alloy C276 (2.4819)		GQ

1) Product Configurator, order code for "Process connection"

Process connections for
PMC71 with internal process
isolating diaphragm -
height H

Description	Height H
Standard height	26 mm (1.02 in)
Device with Ex d[ia], CSA XP or FM XP	96 mm (3.78 in)
High-temperature version	106 mm (4.17 in)
High-temperature version with Ex d[ia], CSA XP or FM XP	176 mm (6.93 in)

Process connections for
PMC71 with flush-mounted
process isolating diaphragm

Threaded connection DIN 13

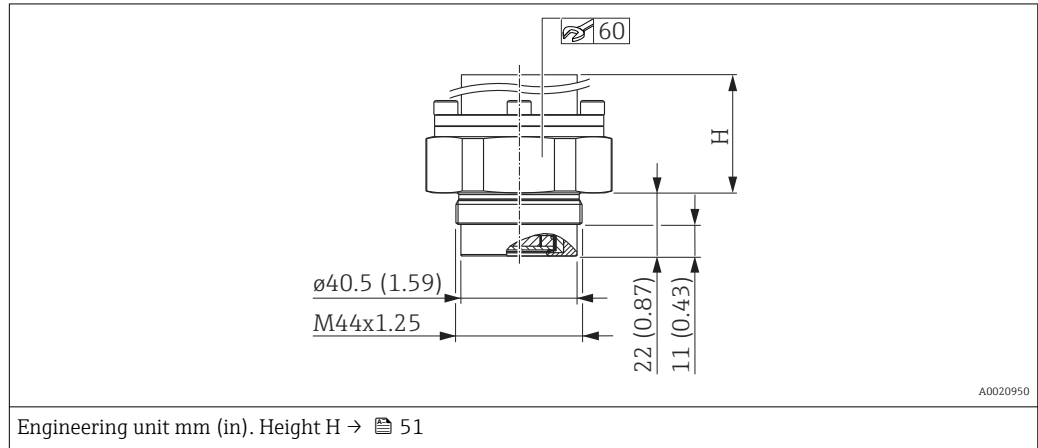

Description	Material	Weight	Option ¹⁾
		kg (lb)	
DIN 13 M44 x 1.25	AISI 316L	0.63 (1.39)	1R
	Alloy C276 (2.4819)		1S

1) Product Configurator, order code for "Process connection"

Threaded connection ISO 228 G

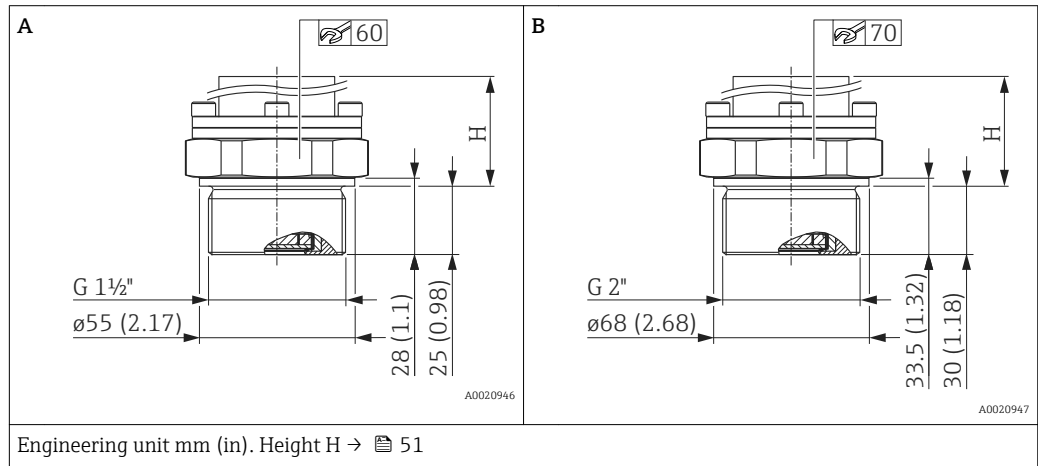

Item	Description	Material	Weight	Option ¹⁾
			kg (lb)	
A	Thread ISO 228 G 1 1/2" A	AISI 316L	0.63 (1.39)	1G
		Alloy C276 (2.4819)		1H
		Monel (2.4360)		1J
B	Thread ISO 228 G 2" A	AISI 316L	0.63 (1.39)	1K
		Alloy C276 (2.4819)		1L
		Monel (2.4360)		1M

1) Product Configurator, order code for "Process connection"

Process connections for
PMC71 with flush-mounted
process isolating diaphragm

Threaded connection ANSI

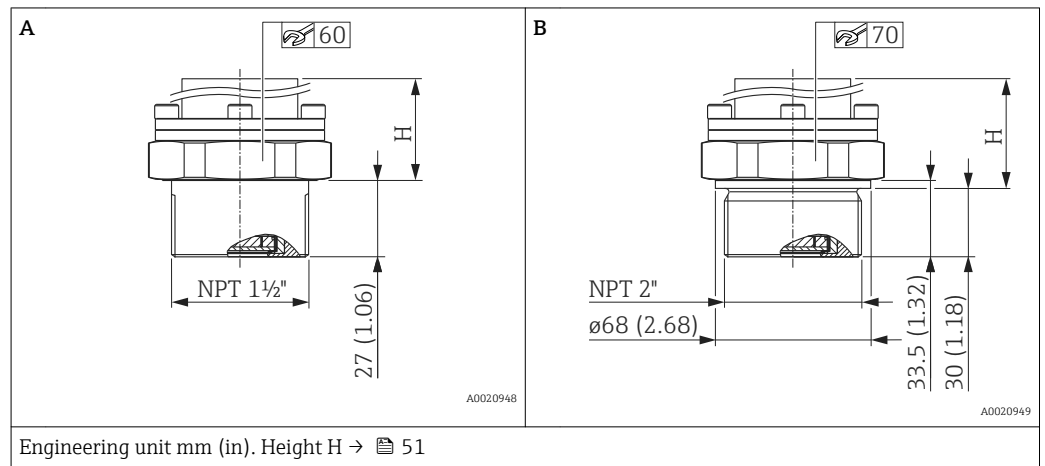

Item	Description	Material	Weight	Approval ¹⁾	Option ²⁾
			kg (lb)		
A	ANSI 1 1/2" MNPT	AISI 316L (CRN)	0.63 (1.39)	CRN	2D
		Alloy C276 (2.4819) (CRN)		CRN	2E
		Monel (2.4360)		-	2F
B	ANSI 2" MNPT	AISI 316L (CRN)		CRN	2G
		Alloy C276 (2.4819) (CRN)		CRN	2H
		Monel (2.4360)		-	2J

- 1) CSA approval: Product Configurator, order code for "Approval"
- 2) Product Configurator, order code for "Process connection"

Process connections for
PMC71 with flush-mounted
process isolating diaphragm
- height H

Description	Height H
High-temperature version	86 mm (3.39 in)
High-temperature version with Ex d[ia], CSA XP or FM XP	151 mm (5.94 in)

Process connections for
PMC71 with flush-mounted
process isolating diaphragm

EN/DIN flanges, connection dimensions in accordance with EN 1092-1/DIN 2527

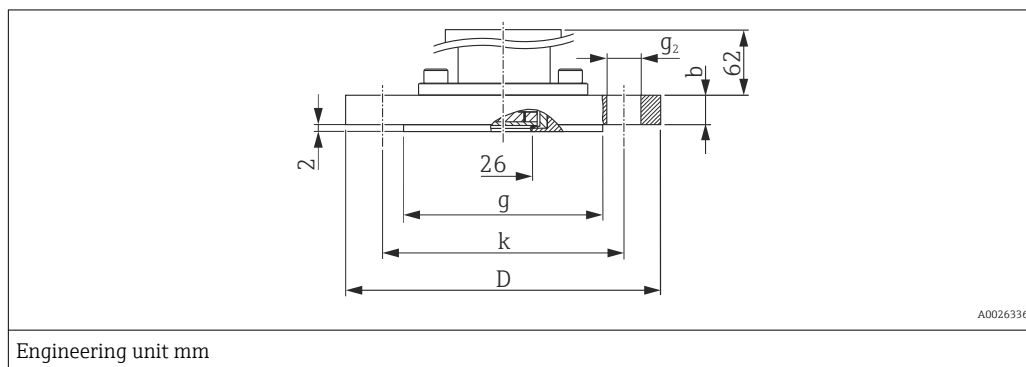

Flange							Boltholes			Weight	Option ¹⁾
Material	Nominal diameter	Nominal pressure	Shape ²⁾	D	Thickness	Raised face	Number	g ₂	Hole circle		
					b	g			k		
				mm	mm	mm		mm	mm	kg (lb)	
AISI 316L	DN 25	PN 10-40	B1 (D)	115	18	68	4	14	85	1.4 (3.09)	BA
AISI 316L	DN 32	PN 10-40	B1 (D)	140	18	78	4	18	100	2.0 (4.41)	CP
AISI 316L	DN 40	PN 10-40	B1 (D)	150	18	88	4	18	110	2.4 (5.29)	CQ
AISI 316L	DN 50	PN 10-40	B1 (D)	165	20	102	4	18	125	3.2 (7.06)	B3
PVDF	DN 50	PN 10-16	B1 (D)	165	21.4	102	4	18	125	0.6 (1.32)	BR
AISI 316L	DN 50	PN 63	B2 (E)	180	26	102	4	22	135	4.6 (10.14)	C3
PVDF	DN 80	PN 10-16	B1 (D)	200	21.4	138	8	18	160	1.0 (2.21)	BS
AISI 316L	DN 80	PN 10-40	B1 (D)	200	24	138	8	18	160	5.4 (11.91)	B4

1) Product Configurator, order code for "Process connection"

2) Description as per DIN 2527 provided in brackets

ASME flanges, connection dimensions in accordance with ASME B 16.5, raised face RF

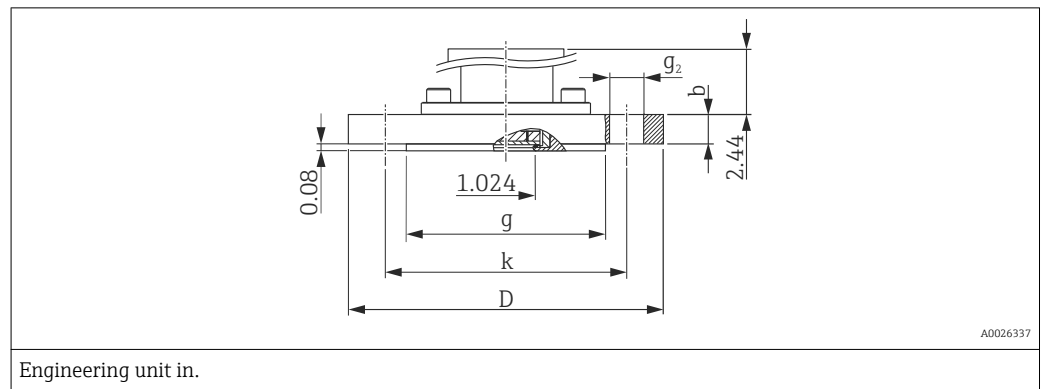

Flange						Boltholes			Weight	Approval ¹⁾	Option ²⁾
Material	Nominal diameter	Class	D	Thickness	Raised face	Number	g ₂	Hole circle			
				b	g				k		
	[in]	[lb./sq.in]	[in]	[in]	[in]		[in]	[in]	[kg (lb)]		
AISI 316/316L ³⁾	1	150	4.25	1.18	2	4	0.62	3.12	0.9 (1.98)	-	AA ⁴⁾
AISI 316/316L ³⁾	1	300	4.88	1.18	2	4	0.75	3.5	1.4 (3.09)	-	AB ⁴⁾
AISI 316/316L ³⁾	1 ½	150	5	0.69	2.88	4	0.62	3.88	1.0 (2.21)	CRN	AE
AISI 316/316L ³⁾	1 ½	300	6.12	0.81	2.88	4	0.88	4.5	2.6 (5.73)	CRN	AQ
AISI 316/316L ³⁾	2	150	6	0.75	3.62	4	0.75	4.75	2.4 (5.29)	CRN	AF
ECTFE ⁵⁾	2	150	6	0.75	3.62	4	0.75	4.75	2.4 (5.29)	-	JR
PVDF	2	150	6	0.75	3.62	4	0.75	4.75	0.5 (1.1)	-	A3
AISI 316/316L ³⁾	2	300	6.5	0.88	3.62	8	0.75	5	3.2 (7.06)	CRN	AR
AISI 316/316L ³⁾	3	150	7.5	0.94	5	4	0.75	6	4.9 (10.8)	CRN	AG
ECTFE ⁵⁾	3	150	7.5	0.94	5	4	0.75	6	4.9 (10.8)	-	JS
PVDF	3	150	7.5	0.94	5	4	0.75	6	0.9 (1.98)	-	A4
AISI 316/316L ³⁾	3	300	8.25	1.12	5	8	0.88	6.62	6.8 (14.99)	CRN	AS
AISI 316/316L ³⁾	4	150	9	0.94	6.19	8	0.75	7.5	7.1 (15.66)	CRN	AH
ECTFE ⁵⁾	4	150	9	0.94	6.19	8	0.75	7.5	7.1 (15.66)	-	JT
AISI 316/316L ³⁾	4	300	10	1.25	6.19	8	0.88	7.88	11.6 (25.58)	CRN	AT

- 1) CSA approval: Product Configurator, order code for "Approval"
- 2) Product Configurator, order code for "Process connection"
- 3) Combination of AISI 316 for required pressure resistance and AISI 316L for required chemical resistance (dual rated)
- 4) Screws must be 15 mm (0.59 in) longer than the standard flange screws
- 5) ECTFE coating on AISI 316/316L. When operating in hazardous areas, avoid electrostatic charge on the plastic surfaces.

JIS flanges, connection dimensions in accordance with JIS B 2220 BL, raised face RF

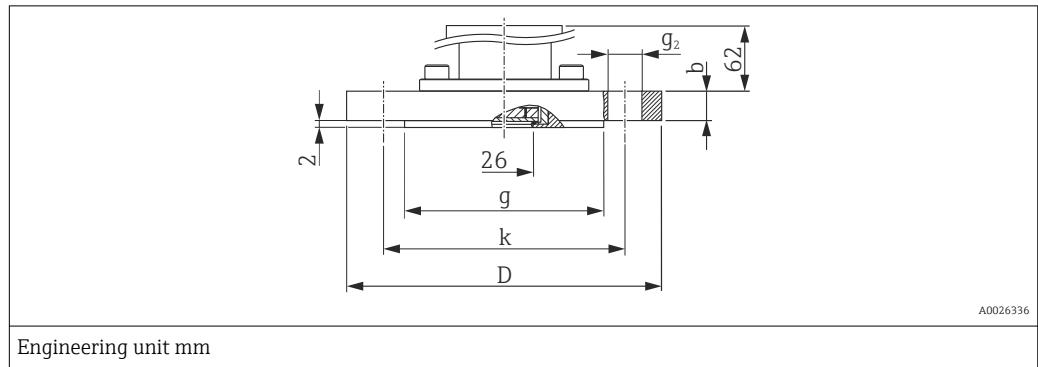

Flange						Boltholes			Weight	Option ¹⁾
Material	Nominal diameter	Nominal pressure	D	Thickness b	Raised face g	Number	g ₂	Hole circle k		
			mm	mm	mm			mm	mm	kg (lb)
AISI 316L (1.4435)	50 A	10 K	155	16	96	4	19	120	2.0 (4.41)	KF
	80 A	10 K	185	18	127	8	19	150	3.3 (7.28)	KL
	100 A	10 K	210	18	151	8	19	175	4.4 (9.7)	KH

1) Product Configurator, order code for "Process connection"

Hygienic process connections for PMC71 with flush-mounted process isolating diaphragm

Many process connections with an EPDM or HNBR seal are approved for the PMC71 in accordance with the guidelines of the 3A Sanitary Standard. To ensure that the 3A approval is valid for the PMC71 version, a 3A-approved process connection together with an EPDM or HNBR seal must be selected when ordering (Product Configurator, order code for "Seal").

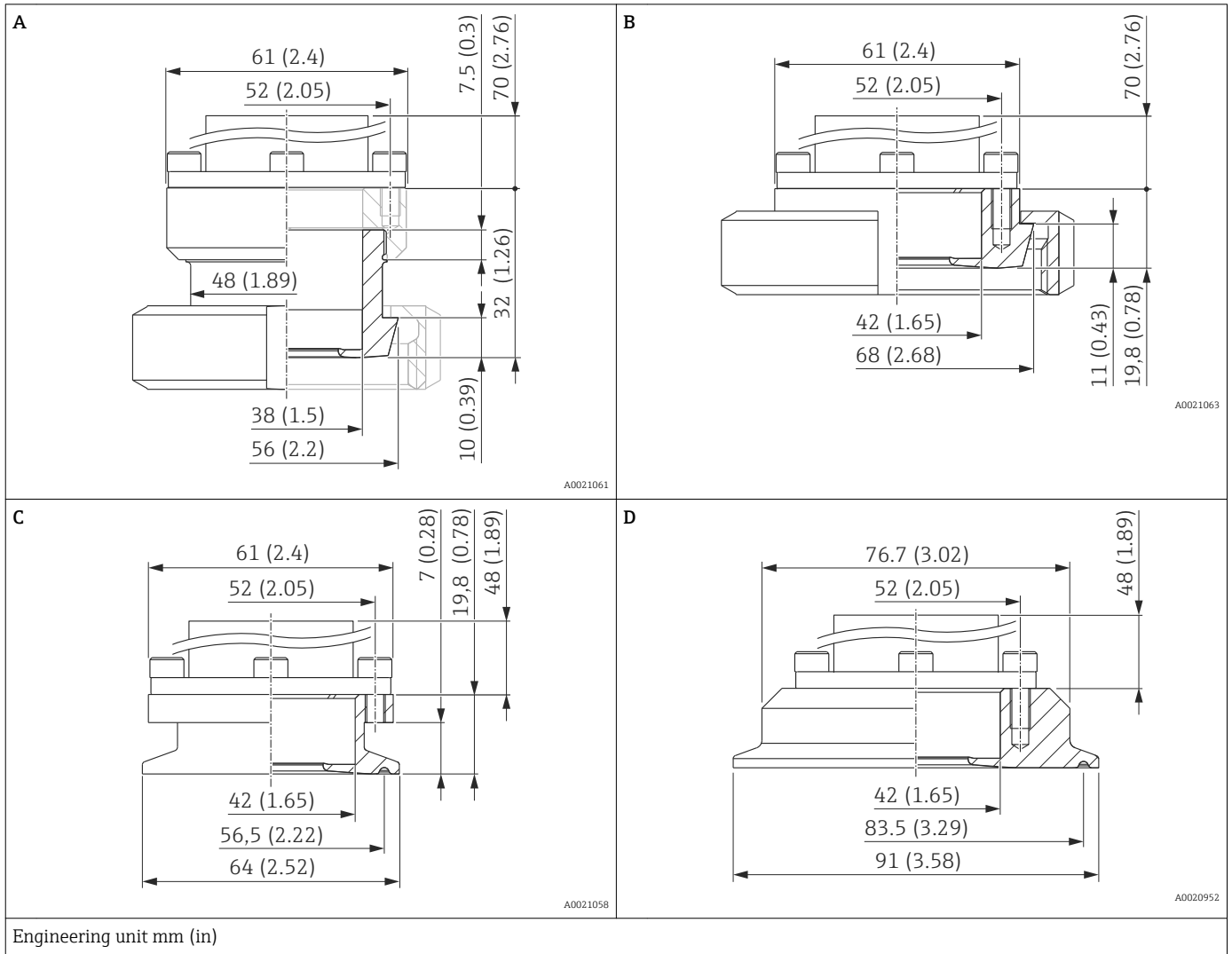

Item	Description	Nominal pressure	Material ¹⁾	Weight	Approval ²⁾	Option ³⁾
				kg (lb)		
A	DIN 11851 DN 40 PN 25, with HNBR or EPDM seal	PN 25	AISI 316L (1.4435)	0.7 (1.54)	EHEDG, 3A, CRN	MP ⁴⁾
B	DIN 11851 DN 50 PN 25, with HNBR or EPDM seal	PN 25		0.9 (1.98)		MR ⁴⁾
C	Tri-Clamp ISO 2852 DN 51 (2"), with HNBR or EPDM seal	PN 40 ⁵⁾		0.7 (1.54)	EHEDG, 3A, CRN	TD ⁴⁾
D	Tri-Clamp ISO 2852 DN 76.1 (3"), with NBR or EPDM seal	PN 40 ⁵⁾		0.9 (1.98)		TF ⁴⁾

- 1) Delta-ferrite content < 1 %. Roughness of wetted surfaces $R_a < 0.80 \mu\text{m}$ (31.5 μin) as standard. Lower surface roughness on request.
- 2) CSA approval: Product Configurator, order code for "Approval"
- 3) Product Configurator, order code for "Process connection"
- 4) Endress+Hauser supplies these slotted nuts in stainless steel AISI 304 (DIN/EN material number 1.4301) or in AISI 304L (DIN/EN material number 1.4307).
- 5) Restricted nominal pressure (13.8 bar (200 psi)) for the following approvals: Product Configurator, order code for "Approval", option "E", "U" and "V".

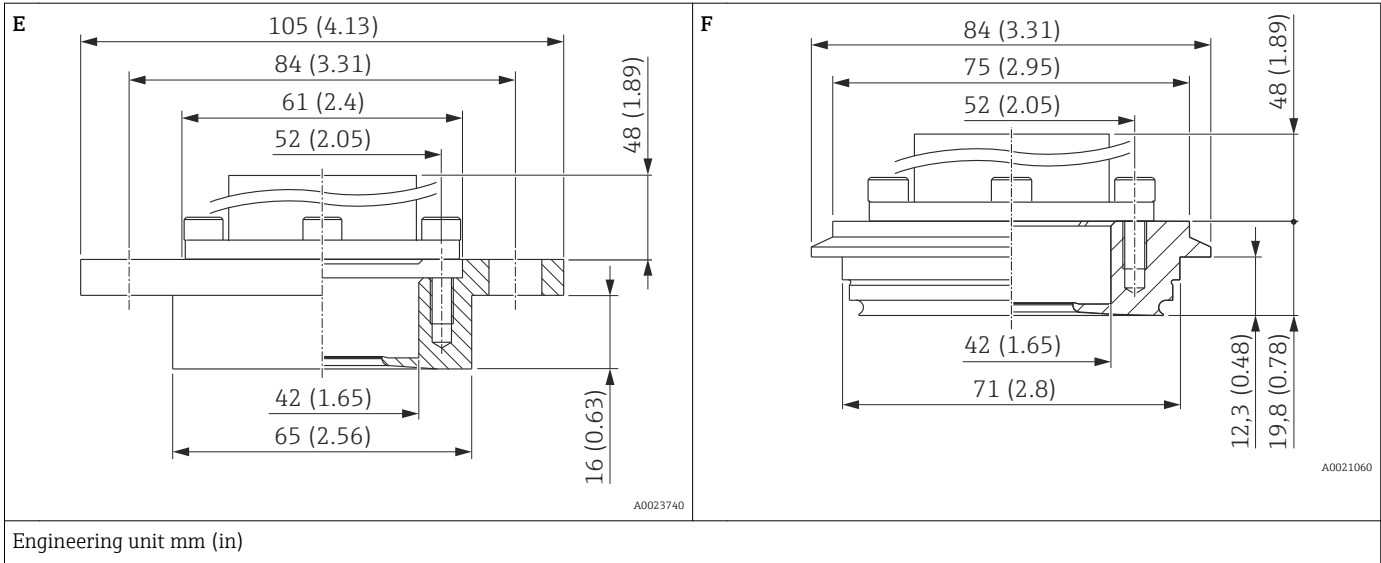

Item	Description	Nominal pressure	Material ¹⁾	Weight	Approval ²⁾	Option ³⁾
				kg (lb)		
E	DRD DN50 (65 mm) with HNBR or EPDM seal	PN 25	AISI 316L (1.4435)	0.9 (1.98)	EHEDG	TK ⁴⁾
F	Varivent type N for pipes 40 – 162, with HNBR or EPDM seal	PN 40		1 (2.21)		EHEDG, 3A, CRN

- 1) Delta-ferrite content < 1 %. Roughness of wetted surfaces $R_a < 0.80 \mu\text{m}$ (31.5 μin) as standard. Lower surface roughness on request.
- 2) CSA approval: Product Configurator, order code for "Approval"
- 3) Product Configurator, order code for "Process connection"
- 4) Endress+Hauser supplies these slotted nuts in stainless steel AISI 304 (DIN/EN material number 1.4301) or in AISI 304L (DIN/EN material number 1.4307).

Process connections for PMP71 with internal process isolating diaphragm

Threaded connection ISO 228 G

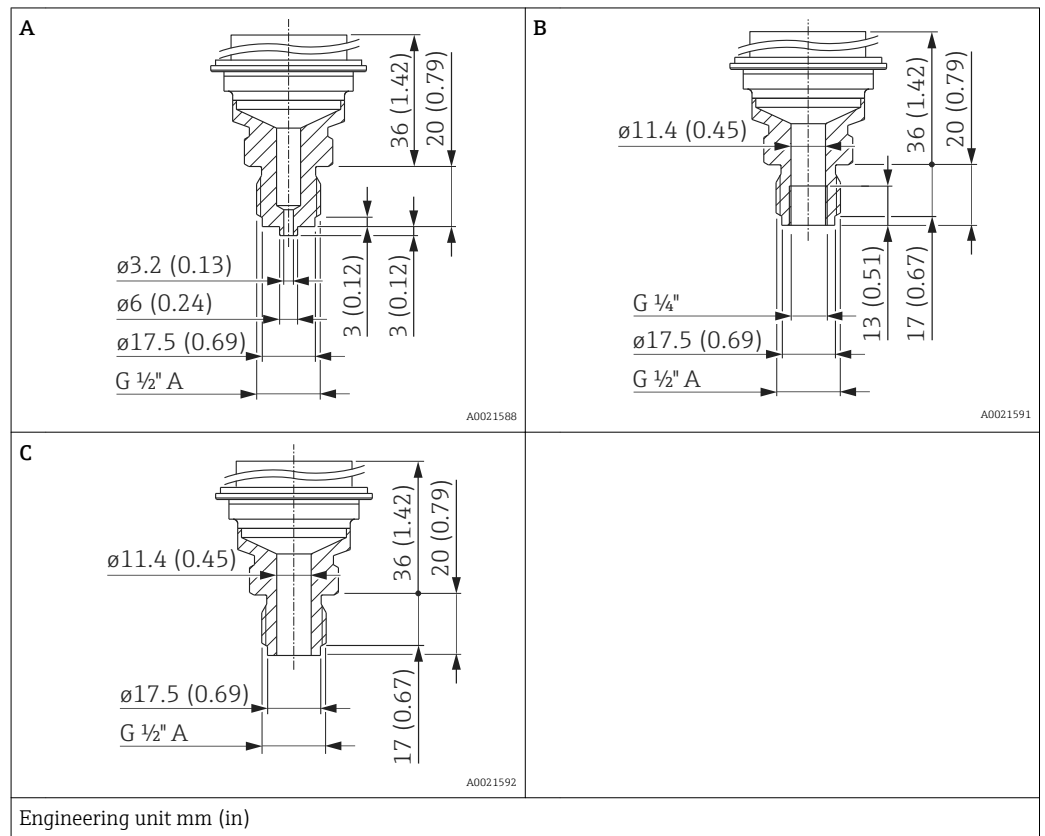

Item	Description	Material	Weight	Option ¹⁾
			kg (lb)	
A	Thread ISO 228 G 1/2" A EN 837	AISI 316L	0.63 (1.39)	GA
		Alloy C276 (2.4819)		GB
B	Thread ISO 228 G 1/2" A, G 1/4" (internal)	AISI 316L		GE
		Alloy C276 (2.4819)		GF
C	Thread ISO 228 G 1/2" A, Hole 11.4 mm (0.45 in)	AISI 316L		GH
		Alloy C276 (2.4819)		GJ

1) Product Configurator, order code for "Process connection"

Process connections for PMP71 with internal process isolating diaphragm

Threaded connection ANSI

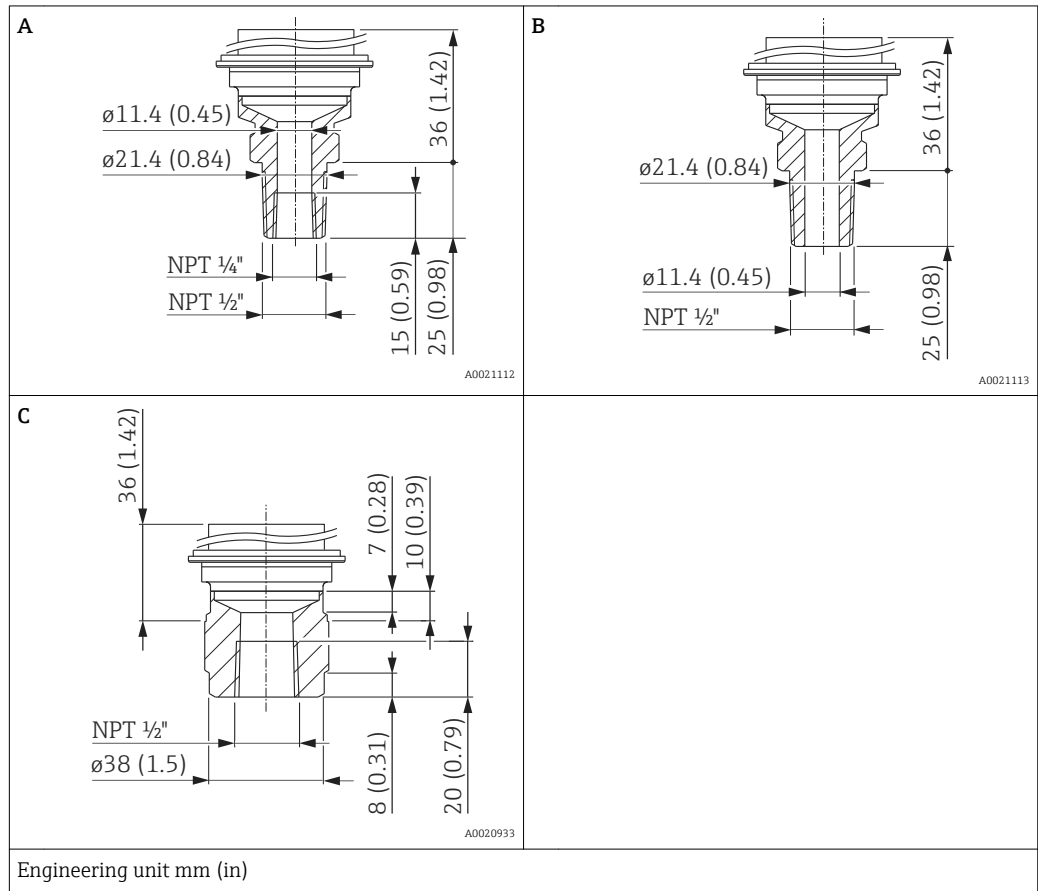

Item	Description	Material	Weight	Approval ¹⁾	Option ²⁾	
			kg (lb)			
A	ANSI 1/2" MNPT, 1/4" FNPT	AISI 316L	0.63 (1.39)	CRN	RA	
		Alloy C276 (2.4819)		CRN	RB	
B	ANSI 1/2" MNPT, Hole 11.4 mm (0.45 in) = 400 bar (6 000 psi) Hole 3.2 mm (0.13 in) = 700 bar (10 500 psi)	AISI 316L		CRN	RD	
		Alloy C276 (2.4819)		CRN	RE	
C	ANSI 1/2" FNPT	AISI 316L		0.7 (1.54)	CRN	RH
		Alloy C276 (2.4819)			CRN	RJ

1) CSA approval: Product Configurator, order code for "Approval"
 2) Product Configurator, order code for "Process connection"

Process connections for PMP71 with internal process isolating diaphragm

Threaded connection JIS

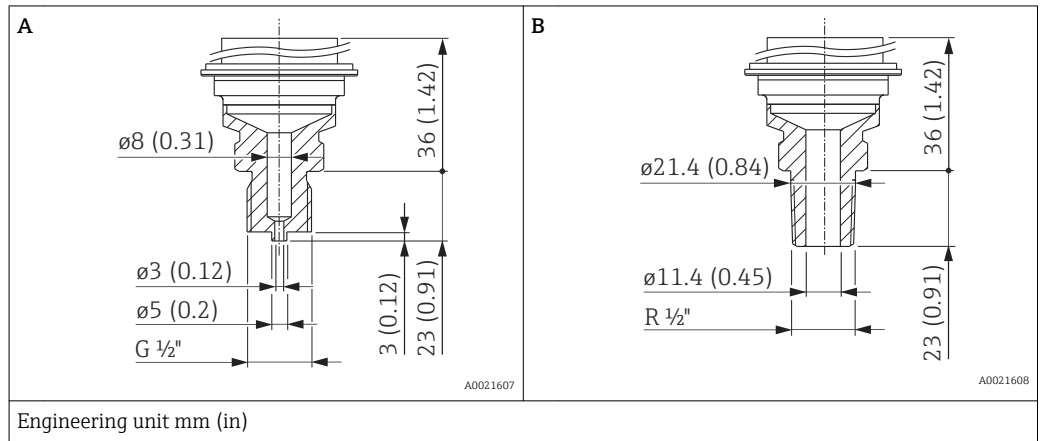

Item	Description	Material	Weight		Option ¹⁾
			kg	(lb)	
A	JIS B0202 G 1/2" (male)	AISI 316L	0.6	(1.32)	GL
B	JIS B0203 R 1/2" (male)				RL

1) Product Configurator, order code for "Process connection"

Threaded connection DIN 13

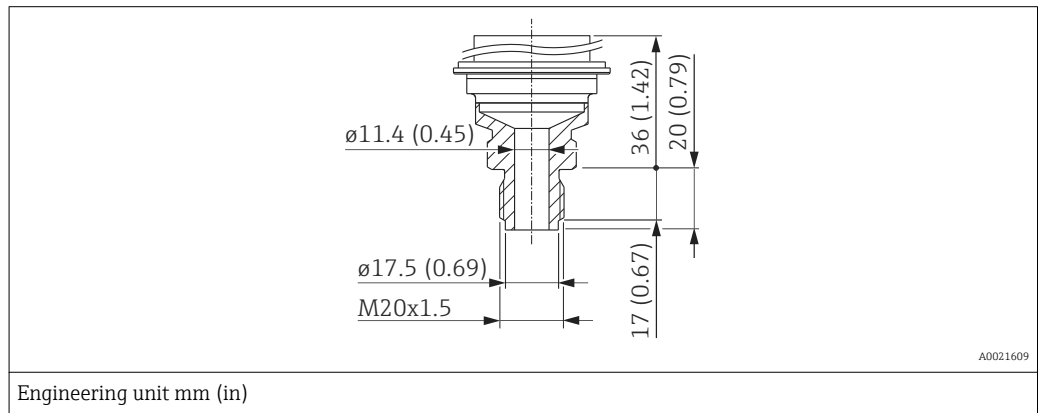

Description	Material	Weight		Option ¹⁾
		kg	(lb)	
DIN 13 M20 x 1.5, EN 837 11.4 mm (0.45 in)	AISI 316L	0.6	(1.32)	GP
	Alloy C276 (2.4819)			GQ

1) Product Configurator, order code for "Process connection"

Process connections for PMP71 with flush-mounted process isolating diaphragm Threaded connection ISO 228 G

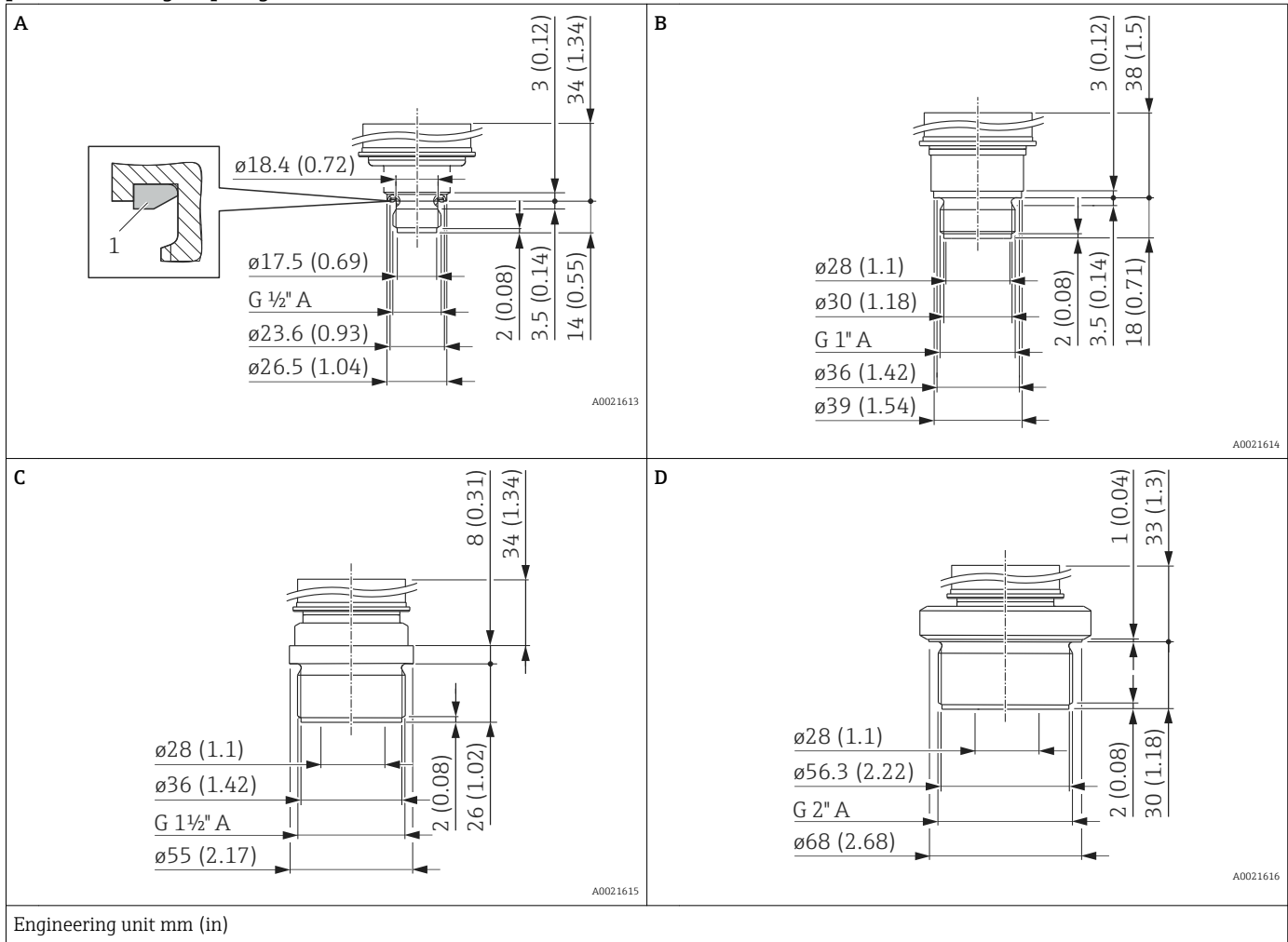

Item	Description	Material	Weight	Option ¹⁾
			kg (lb)	
A	Thread ISO 228 G 1/2" A, DIN 3852 FKM seal (item 1) pre-installed	AISI 316L	0.4 (0.88)	1A
		Alloy C276 (2.4819)		1B
B	Thread ISO 228 G 1" A	AISI 316L	0.7 (1.54)	1D
		Alloy C276 (2.4819)		1E
C	Thread ISO 228 G 1 1/2" A	AISI 316L	1.1 (2.43)	1G
		Alloy C276 (2.4819)		1H
D	Thread ISO 228 G 2" A	AISI 316L	1.5 (3.31)	1K
		Alloy C276 (2.4819)		1L

1) Product Configurator, order code for "Process connection"

Threaded connection DIN

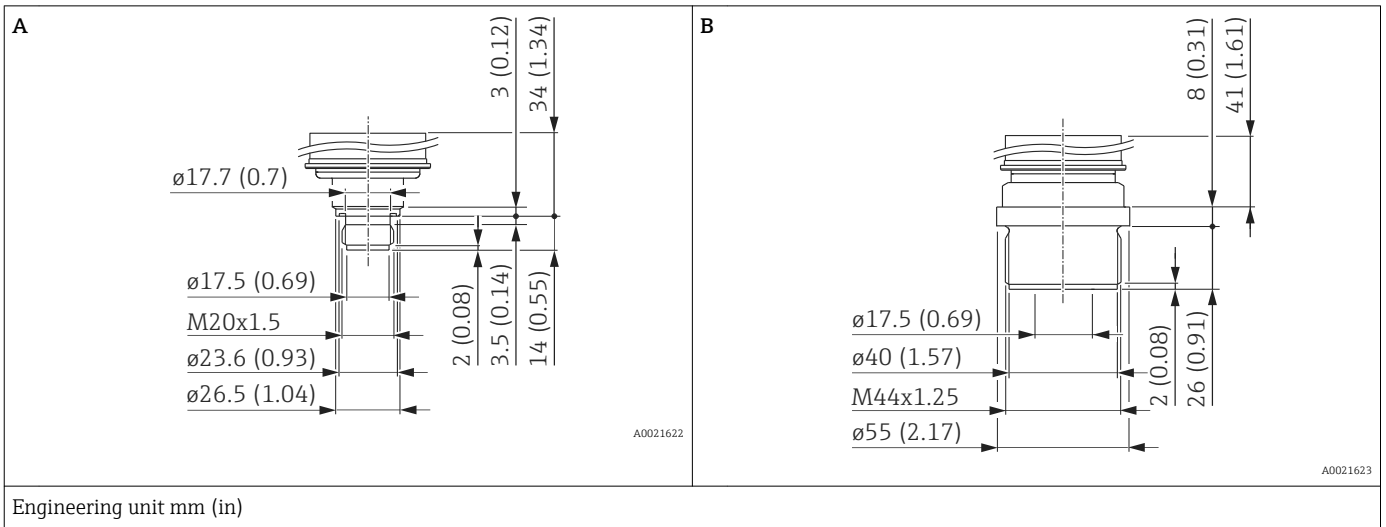

Item	Description	Material	Weight	Option ¹⁾
			kg (lb)	
A	Thread DIN 16288 M20	AISI 316L	0.4 (0.88)	1N
		Alloy C276 (2.4819)		1P
B	Thread DIN 13 M44 x 1.25	AISI 316L	1.1 (2.43)	1R
		Alloy C276 (2.4819)		1S

1) Product Configurator, order code for "Process connection"

Process connections for
PMP71 with flush-mounted
process isolating diaphragm

Threaded connection ANSI

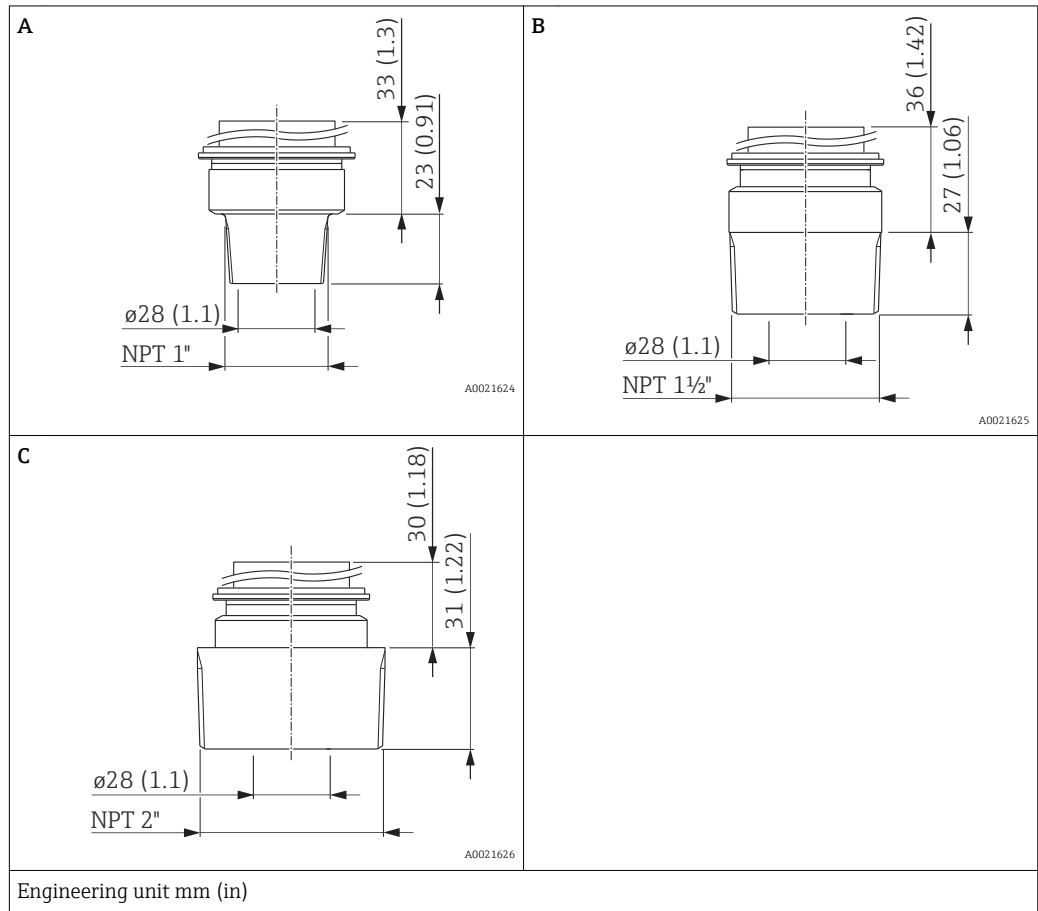

Item	Description	Material	Weight	Approval ¹⁾	Option ²⁾
			kg (lb)		
A	ANSI 1" MNPT	AISI 316L	0.7 (1.54)	CRN	2A
		Alloy C276 (2.4819)			2B
B	ANSI 1 1/2" MNPT	AISI 316L	1 (2.21)	CRN	2D
		Alloy C276 (2.4819)			2E
C	ANSI 2" MNPT	AISI 316L	1.3 (2.87)	CRN	2G
		Alloy C276 (2.4819)			2H

1) CSA approval: Product Configurator, order code for "Approval"
 2) Product Configurator, order code for "Process connection"

Process connections for PMP71 with flush-mounted process isolating diaphragm

EN/DIN flanges, connection dimensions in accordance with EN 1092-1/DIN 2527

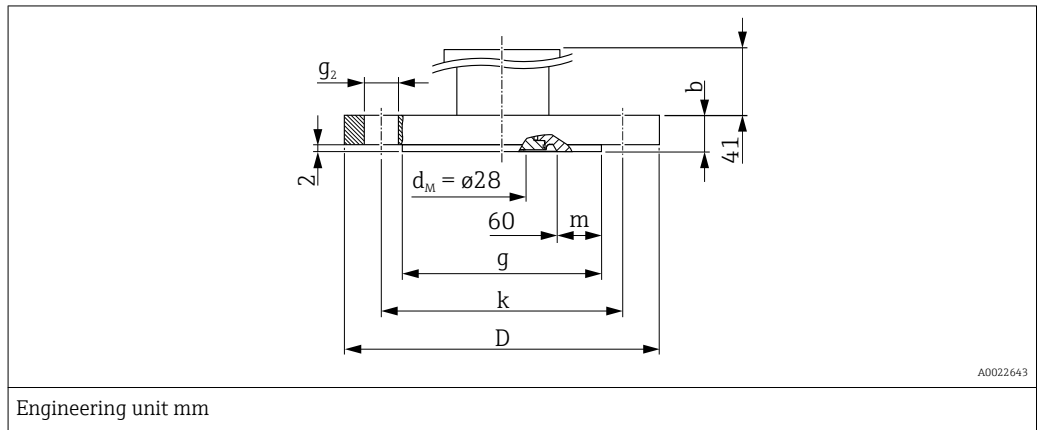

Flange ¹⁾							Boltholes			Weight Flange	Option ²⁾
Nominal diameter	Nominal pressure	Shape ³⁾	D	Thickness	Raised face	Width of Raised face	Number	g ₂	Hole circle		
				b	g	m			k		
			[mm]	[mm]	[mm]	[mm]		[mm]	[mm]	[kg]	
DN 25	PN 10-40	B1 (D)	115	18	68 ⁴⁾	4	4	14	85	1.2 (2.65)	CN
DN 32	PN 10-40	B1 (D)	140	18	78 ⁴⁾	9	4	18	100	1.9 (4.19)	CP
DN 40	PN 10-40	B1 (D)	150	18	88 ⁴⁾	14	4	18	110	2.2 (4.85)	CQ
DN 50	PN 10-40	B1 (D)	165	20	102	-	4	18	125	3.0 (6.62)	B3
DN 80	PN 10-40	B1 (D)	200	24	138	-	8	18	160	5.3 (11.69)	B4

- 1) Material: AISI 316L
- 2) Product Configurator, order code for "Process connection"
- 3) Name as per DIN 2527 provided in brackets
- 4) With these process connections the raised face is smaller than described in the standard. Due to a smaller raised face a special seal must be used. For further information, please contact a seal manufacturer or your local Endress+Hauser Sales Center.

Process connections for PMP71 with flush-mounted process isolating diaphragm

ASME flanges, connection dimensions in accordance with ASME B 16.5, raised face RF*

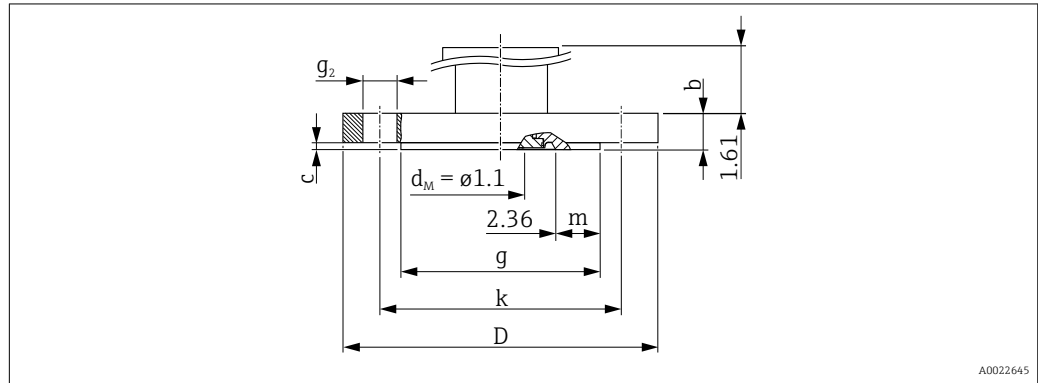

A0022645

Engineering unit in.
(*all apart from AN, see table below)

Flange ¹⁾							Boltholes			Weight	Approval ²⁾	Option ³⁾
Nominal diameter	Class/nominal pressure	D	Thickness	Raised face	Thickness of raised face	Width of Raised face	Number	g_2	Hole circle			
[in]	lb./sq.in	[in]	b [in]	g [in]	c [in]	m [in]		[in]	k [in]	[kg]		
1	300	4.88	0.69	2 ⁴⁾	0.06	0.2	4	0.75	3.5	1.3 (2.87)	CRN	AN
1 ½	150	5	0.69	2.88 ⁴⁾	0.08	0.52	4	0.62	3.88	1.5 (3.31)	CRN	AE
1 ½	300	6.12	0.81	2.88 ⁴⁾	0.08	0.52	4	0.88	4.5	2.6 (5.73)	CRN	AQ
2	150	6	0.75	3.62	0.08	-	4	0.75	4.75	2.4 (5.29)	CRN	AF
2	300	6.5	0.88	3.62	0.08	-	8	0.75	5	3.2 (7.06)	CRN	AR
3	150	7.5	0.94	5	0.08	-	4	0.75	6	4.9 (10.8)	CRN	AG
3	300	8.25	1.12	5	0.08	-	8	0.88	6.62	6.7 (14.77)	CRN	AS
4	150	9	0.94	6.19	0.08	-	8	0.75	7.5	7.1 (15.66)	CRN	AH
4	300	10	1.25	6.19	0.08	-	8	0.88	7.88	11.6 (25.88)	CRN	AT

- 1) Material: AISI 316/316L; Combination of AISI 316 for required pressure resistance and AISI 316L for required chemical resistance (dual rated)
- 2) CSA approval: Product Configurator, order code for "Approval"
- 3) Product Configurator, order code for "Process connection"
- 4) With these process connections the raised face is smaller than described in the standard. Due to a smaller raised face a special seal must be used. For further information, please contact a seal manufacturer or your local Endress+Hauser Sales Center.

Process connections for PMP71 with flush-mounted process isolating diaphragm

JIS flanges, connection dimensions in accordance with JIS B 2220 BL, raised face RF

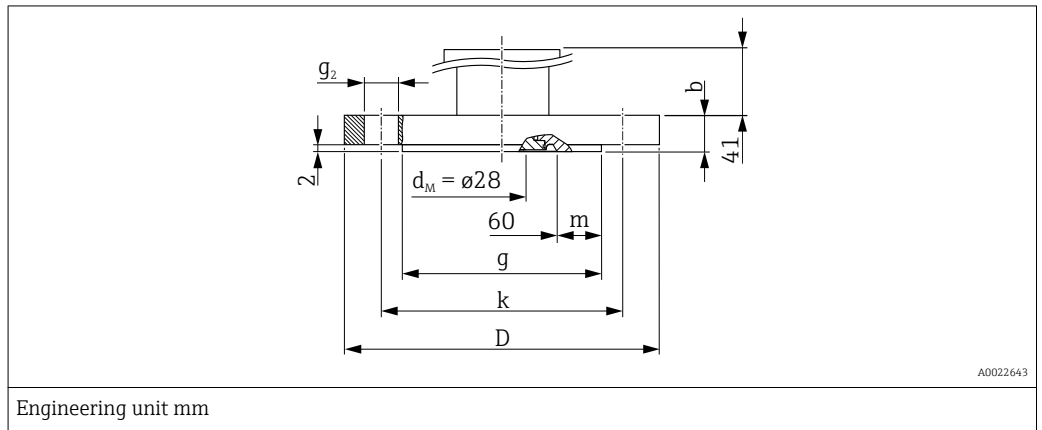

Flange							Boltholes			Weight Flange	Option ¹⁾
Material	Nominal diameter	Class/ Nominal pressure	D	Thickness	Raised face	Width of Raised face	Number	g ₂	Hole circle		
				b	g	m			k		
			[mm]	[mm]	[mm]	[mm]		[mm]	[mm]	[kg]	
AISI 316L	25 A	20 K	125	16	67 ²⁾	3.5	4	19	90	1.5 (3.31)	KA
AISI 316L	50 A	10 K	155	16	96	-	4	19	120	2.0 (4.41)	KF
AISI 316L	80 A	10 K	185	18	127	-	8	19	150	3.3 (7.28)	KL
AISI 316L	100 A	10 K	210	18	151	-	8	19	175	4.4 (9.7)	KH

- 1) Product Configurator, order code for "Process connection"
- 2) With these process connections the raised face is smaller than described in the standard. Due to a smaller raised face a special seal must be used. For further information, please contact a seal manufacturer or your local Endress+Hauser Sales Center.

Process connections for PMP71

Oval flange

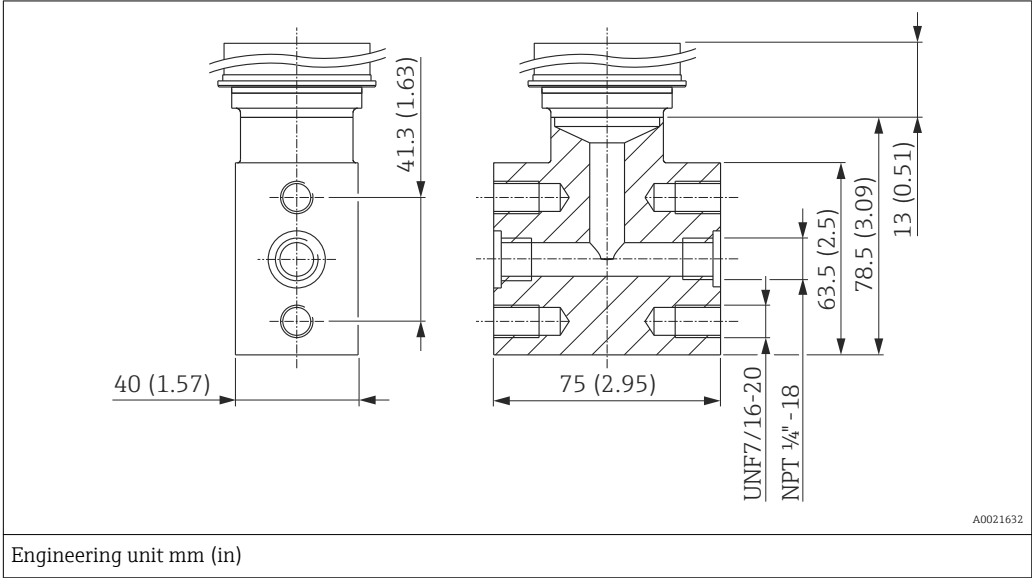

Engineering unit mm (in)

Material	Description	Weight	Approval ¹⁾	Option ²⁾
		kg (lb)		
AISI 316L (1.4404)	Oval flange adapter 1/4-18 NPT as per IEC 61518 Mounting: 7/16-20 UNF	1.9 (4.19)	CRN	UR

1) CSA approval: Product Configurator, order code for "Approval"
 2) Product Configurator, order code for "Process connection"

Process connections for
PMP71

Prepared for diaphragm seal mount

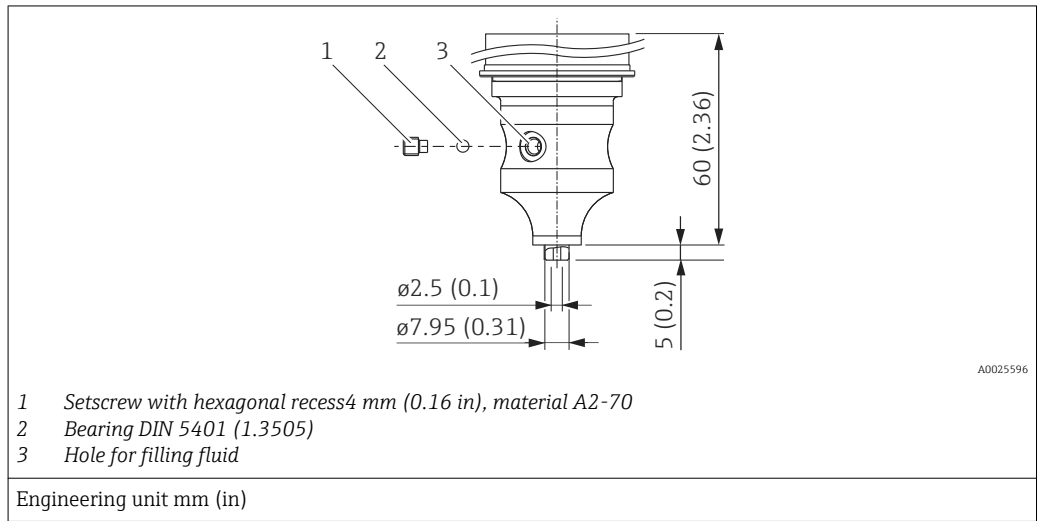

Material	Description	Weight in kg (lb)	Approval ¹⁾	Option ²⁾
AISI 316L (1.4404)	Prepared for diaphragm seal mount	1.9 (4.19)	CRN	U1

- 1) CSA approval: Product Configurator, order code for "Approval"
- 2) Product Configurator, order code for "Process connection"

Process connections for PMP75 with flush-mounted process isolating diaphragm



- The weights of the diaphragm seals are given in the tables. For the weight of the housing, see
- The following drawings are drawings that illustrate how the system works in principle. In other words, the dimensions of a diaphragm seal supplied can deviate from the dimensions given in this document.
- With the use of high-temperature oils the design can deviate strongly.
- Note "Planning instructions, diaphragm seal systems" section → 99
- For further information please contact your local Endress+Hauser Sales Center.

Diaphragm seal cell structure

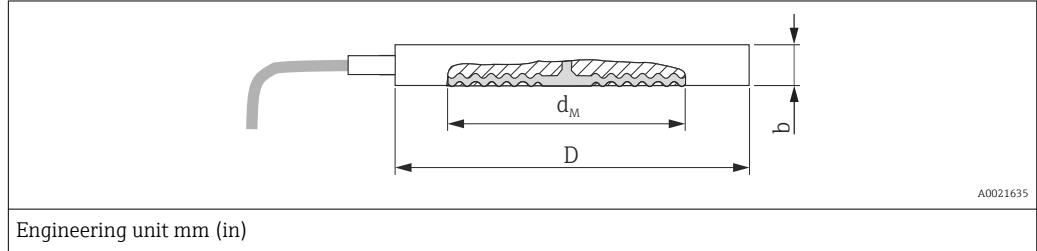

Engineering unit mm (in)

Flange				Diaphragm seal			Approval ¹⁾	Option ²⁾
Material	Nominal diameter	Nominal pressure ³⁾	D	Thickness b	Max. diameter of the process isolating diaphragm d _M	Weight [kg (lb)]		
			[mm]	[mm]	[mm]			
AISI 316L	DN 50	PN 16-400	102	20	59	1.3 (2.87)	-	UI
	DN 80	PN 16-400	138	20	89	2.3 (5.07)	-	UJ
	DN 100	PN 16-400	162	20	89	3.1 (6.84)	-	UK
	[in]	[lb/sq.in]	[in (mm)]	[in (mm)]	[in (mm)]			
	2	150-2500	4.01 (102)	0.79 (20)	2.32 (59)	1.3 (2.87)	CRN	UL
	3	150-2500	5.35 (136)	0.79 (20)	3.50 (89)	2.3 (5.07)	CRN	UM
	4	150-2500	6.22 (158)	0.79 (20)	3.50 (89)	3.1 (6.84)	CRN	UR

1) CSA approval: Product Configurator, order code for "Approval"

2) Product Configurator, order code for "Process connection"

3) The specified nominal pressure applies to the diaphragm seal. The maximum pressure for the measuring device is dependent on the lowest-rated element, with regard to pressure, of the selected components → 43.

PMP75 basic device

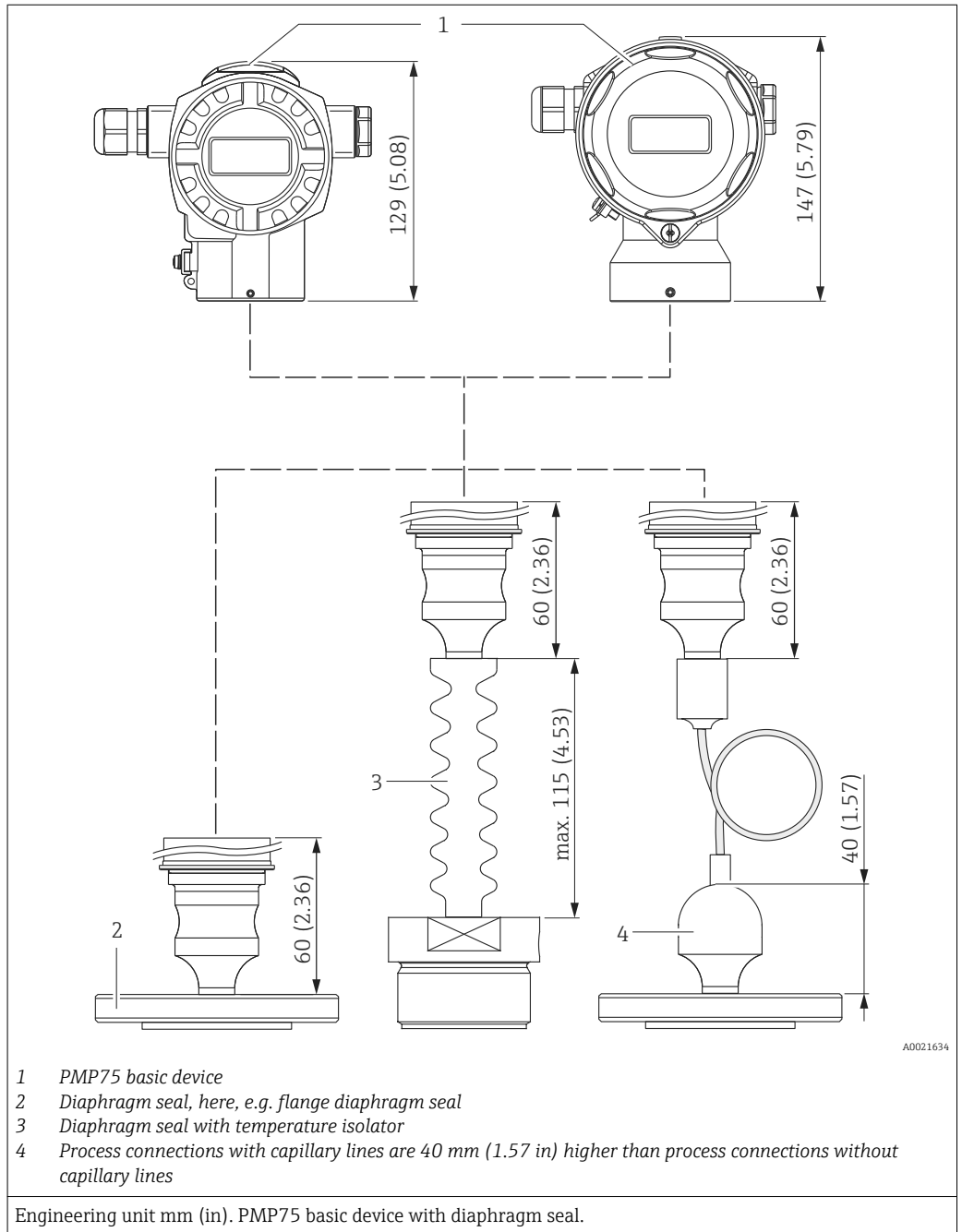

A0021634

Process connections for PMP75 with flush-mounted process isolating diaphragm

Thread ISO 228 and ANSI

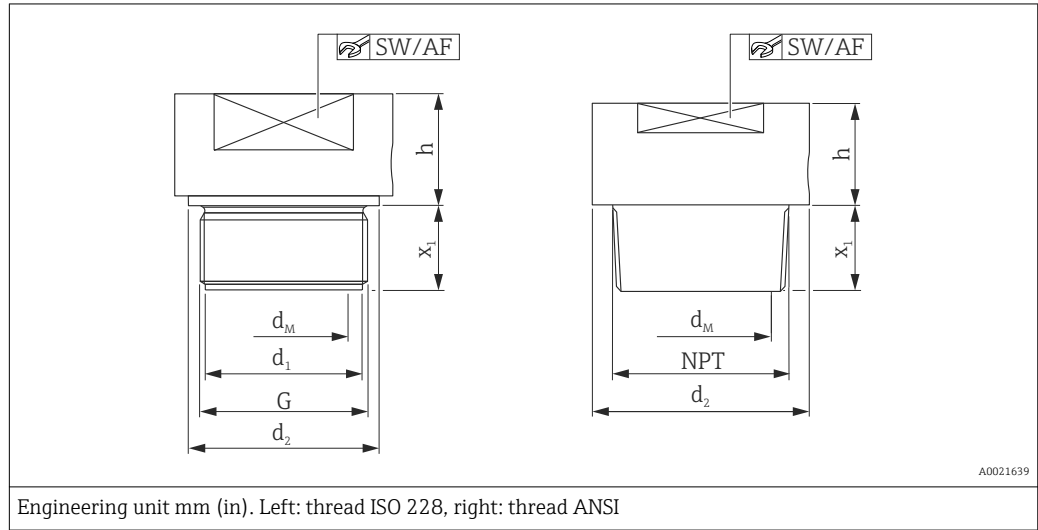

Threaded connection							Diaphragm seal			Approval ¹⁾	Option ²⁾
Material	Thread	Nominal pressure PN	d ₁ [mm]	d ₂ [mm]	Screw-in length [mm]	Across flats SW/AF	Max. diameter of the process isolating diaphragm [mm]	Height	Weight [kg (lb)]		
								h [mm]			
AISI 316L	G 1" A	400	30	39	21 ³⁾	32	30	19	0.4 (0.88)	-	1D
Alloy C276									0.5 (1.1)	-	1E
AISI 316L	G 1 ½" A	400	44	55	30	50	42	20	0.9 (1.98)	-	1G
Alloy C276									1.0 (2.21)	-	1H
AISI 316L	G 2"	400	56	68	30	65	50	20	1.9 (4.19)	-	1K
Alloy C276									2.1 (4.63)	-	1L
AISI 316L	1" MNPT	400	-	48	28	41	24	37	0.6 (1.32)	CRN	2A
Alloy C276									0.7 (1.54)	CRN	2B
AISI 316L	1 ½" MNPT	400	-	60	30	41	36	20	0.9 (1.98)	CRN	2D
Alloy C276									1.0 (2.21)	CRN	2E
AISI 316L	2" MNPT	400	-	78	30	65	38	35	1.8 (3.97)	CRN	2G
Alloy C276									2.0 (4.41)	CRN	2H

- 1) CSA approval: Product Configurator, order code for "Approval"
- 2) Product Configurator, order code for "Process connection"
- 3) 28 mm (1.1 in) in conjunction with high-temperature oil

Process connections for
PMP75 with flush-mounted
process isolating diaphragm

Tri-Clamp ISO 2852

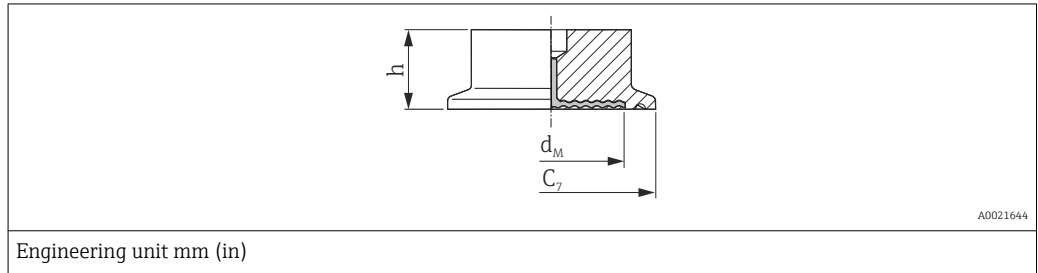

Material ¹⁾	Nominal diameter ISO 2852	Nominal diameter DIN 32676	Nominal diameter	Diameter	Max. diameter of the process isolating diaphragm		Height	Weight	Approval ²⁾	Option ³⁾
					Standard	with TempC membrane				
					C ₇	d _M	d _M	h		
			[in]	[mm]	[mm]	[mm]	[mm]	[kg (lb)]		
AISI 316L	ND 25 / 33.7	DN 25	1	50.5	24	-	37	0.32 (0.71)	EHEDG, 3A, CRN	TB
	ND 38	DN 40	1 ½	50.5	36	36	30	1 (2.21)	EHEDG, 3A, CRN	TC ^{4) 5)}
	ND 51 / 40	DN 50	2	64	48	41	30	1.1 (2.43)	EHEDG, 3A, CRN	TD ^{4) 5)}
	ND 63.5	DN 50	2 ½	77.5	61	61	30	0.7 (1.54)	EHEDG, 3A	TE ⁶⁾
	ND 76.1	-	3	91	73	61	30	1.2 (2.65)	EHEDG, 3A, CRN	TF ⁵⁾

- 1) Surface roughness of the wetted surfaces $R_a < 0.76 \mu\text{m}$ ($29.9 \mu\text{in}$) as standard. Lower surface roughness on request.
- 2) CSA approval: Product Configurator, order code for "Approval"
- 3) Product Configurator, order code for "Process connection"
- 4) Optionally available as an ASME-BPE-compliant diaphragm seal version for use in biochemical processes, surfaces in contact with medium $R_a < 0.38 \mu\text{m}$ ($15 \mu\text{in}$) , electropolished; order using order code for "Additional options", option "P".
- 5) Alternatively available with TempC membrane.
- 6) With TempC membrane

 PN max. = 40 bar (580 psi). The maximum PN depends on the clamp used.

Process connections for
PMP75 with flush-mounted
process isolating diaphragm

Tri-Clamp pipe diaphragm seal ISO 2852

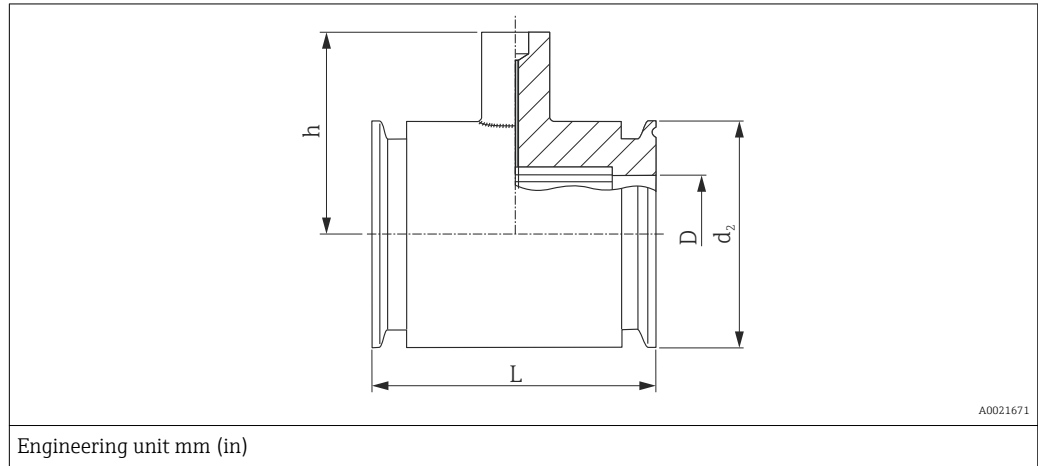

Engineering unit mm (in)

Material ¹⁾	Nominal diameter ISO 2852	Nominal diameter	Nominal pressure	D	d ₂	Height	Installation length	Weight [kg (lb)]	Approval ²⁾	Option ³⁾	
		[in]		[in]	[mm]	[mm]	h				L
		[mm]		[mm]	[mm]	[mm]					
AISI 316L	DN 25	1	PN 40	22.5	50.5	67	126	1.7 (3.75)	3A, CRN	SB	
	DN 38	1 ½	PN 40	35.5	50.5	67	126	1.0 (2.21)	3A, CRN	SC ⁴⁾	
	DN 51	2	PN 40	48.6	64	79	100	1.7 (3.75)	3A, CRN	SD ⁴⁾	

- 1) Surface roughness of the wetted surfaces $R_a < 0.8 \mu\text{m}$ ($31.5 \mu\text{in}$) as standard.
- 2) CSA approval: Product Configurator, order code for "Approval"
- 3) Product Configurator, order code for "Process connection"
- 4) incl. 3.1 and pressure test in accordance with the Pressure Equipment Directive, category II

Hygienic process connections for PMP75 with flush-mounted process isolating diaphragm **Varivent for pipes**

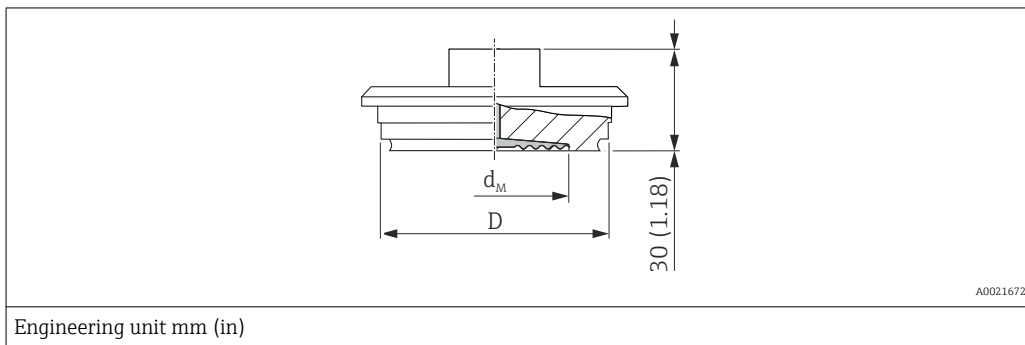

Material ¹⁾	Description	Nominal pressure	D	Max. diameter of the process isolating diaphragm		Weight	Approval	Option ²⁾
				Standard	with TempC membrane			
				d _M	d _M			
				[mm]	[mm]			
AISI 316L	Type F for pipes DN 25 - DN 32	PN 40	50	34	36	0.4 (0.88)	EHEDG, 3A	TU ³⁾
AISI 316L	Type N for pipes DN 40 - DN 162	PN 40	68	58	61	0.8 (1.76)	EHEDG, 3A	TR ^{4) 5)}

- 1) Surface roughness of the wetted surfaces $R_a < 0.76 \mu\text{m}$ ($29.9 \mu\text{in}$) as standard.
- 2) Product Configurator, order code for "Process connection"
- 3) With TempC membrane
- 4) Optionally available as an ASME-BPE-compliant diaphragm seal version for use in biochemical processes, surfaces in contact with medium $R_a < 0.38 \mu\text{m}$ ($15 \mu\text{in}$), electropolished; order using order code for "Additional options", option "P". Reduced surface roughness on request.
- 5) Alternatively available with TempC membrane.

Hygienic process connections for PMP75 with flush-mounted process isolating diaphragm DRD DN50 (65 mm)

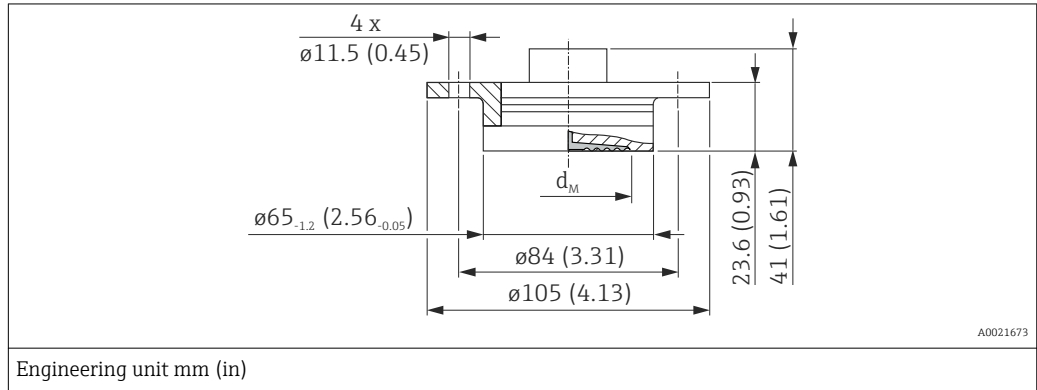

Material ¹⁾	Nominal pressure	Max. diameter of the process isolating diaphragm		Weight	Option ²⁾
		Standard	with TempC membrane		
		d _M	d _M	[kg (lb)]	
		[mm]	[mm]		
AISI 316L	PN 25	50	48	0.75 (1.65)	TK ³⁾

- 1) Surface roughness of the wetted surfaces R_a < 0.76 µm (29.9 µin) as standard.
- 2) Product Configurator, order code for "Process connection"
- 3) Alternatively available with TempC membrane.

SMS nozzles with coupling nut

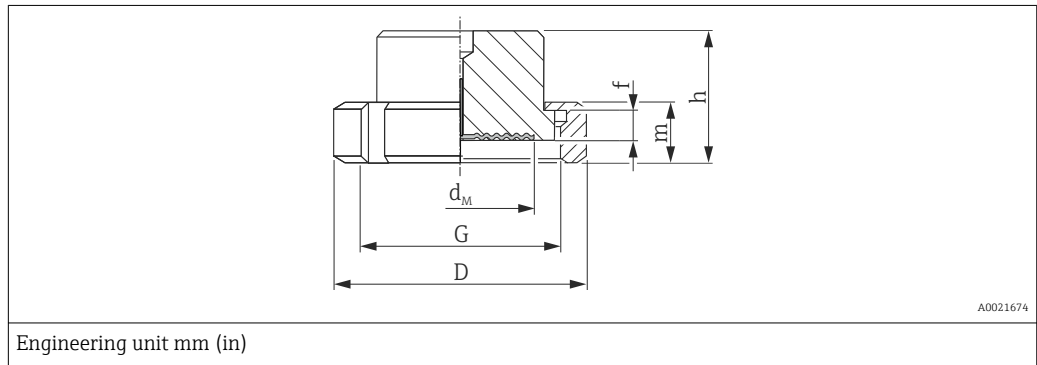

Material ¹⁾	Nominal diameter	Nominal pressure	D	Nozzle height	Thread	Height	Height	max. diameter of the diaphragm	Weight	Approval	Option ²⁾
				f	G	m	h				
				[mm]	[mm]	[mm]	[mm]	[mm]			
AISI 316L	1	PN 25	54	3.5	Rd 40 - 1/6	20	42.5	24	0.25 (0.55)	3A, EHEDG	TG
	1 ½	PN 25	74	4	Rd 60 - 1/6	25	57	36	0.65 (1.43)	3A, EHEDG	TH ³⁾
	2	PN 25	84	4	Rd 70 - 1/6	26	62	48	1.05 (2.32)	3A, EHEDG	TI ³⁾

- 1) Surface roughness of the wetted surfaces R_a < 0.76 µm (29.9 µin) as standard.
- 2) Product Configurator, order code for "Process connection"
- 3) Alternatively available with TempC diaphragm.

APV-RJT nozzles with coupling nut

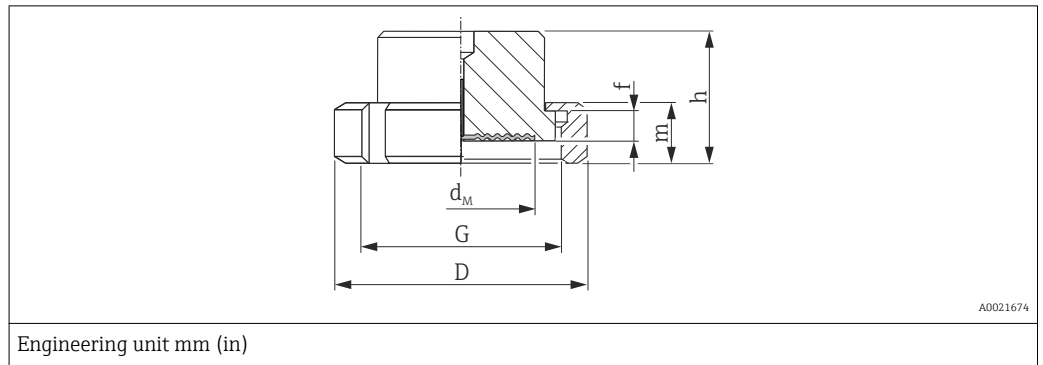

Material ¹⁾	Nominal diameter	Nominal pressure	D	Nozzle height	Thread	Height	Height	Max. diameter of the process isolating diaphragm	Weight	Option ²⁾
						m	h			
	[in]	[bar]	[mm]	[mm]	G	[mm]	[mm]	d _M	[kg (lb)]	
AISI 316L	1	PN 40	77	6.5	1 13/16 - 1/8"	22	42.6	21	0.45 (0.99)	TL
	1 1/2	PN 40	72	6.4	2 5/16 - 1/8"	22	42.6	28	0.75 (1.65)	TM
	2	PN 40	86	6.4	2 7/8 - 1/8"	22	42.6	38	1.2 (2.65)	TN

- 1) Surface roughness of the wetted surfaces $R_a < 0.8 \mu\text{m}$ (31.5 μin) as standard.
- 2) Product Configurator, order code for "Process connection"

APV-ISS nozzles with coupling nut

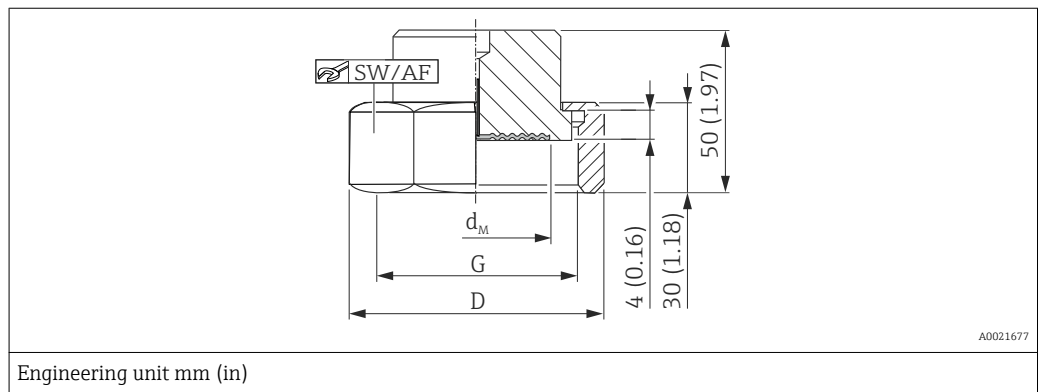

Material ¹⁾	Nominal diameter	Nominal pressure	D	Thread	Across flats	Max. diameter of the process isolating diaphragm	Weight	Option ²⁾
					AF			
	[in]	[bar]	[mm]	G	[mm]	d _M	[kg (lb)]	
AISI 316L	1	PN 40	54.1	1 1/2" - 1/8"	46.8	24	0.4 (0.88)	TP
	1 1/2	PN 40	72	2" - 1/8"	62	34	0.6 (1.32)	TQ
	2	PN 40	89	2 1/2" - 1/8"	77	45	1.1 (2.43)	TS

- 1) Surface roughness of the wetted surfaces $R_a < 0.8 \mu\text{m}$ (31.5 μin) as standard.
- 2) Product Configurator, order code for "Process connection"

Hygienic process connections for PMP75 with flush-mounted process isolating diaphragm

Taper adapter with coupling nut, DIN 11851

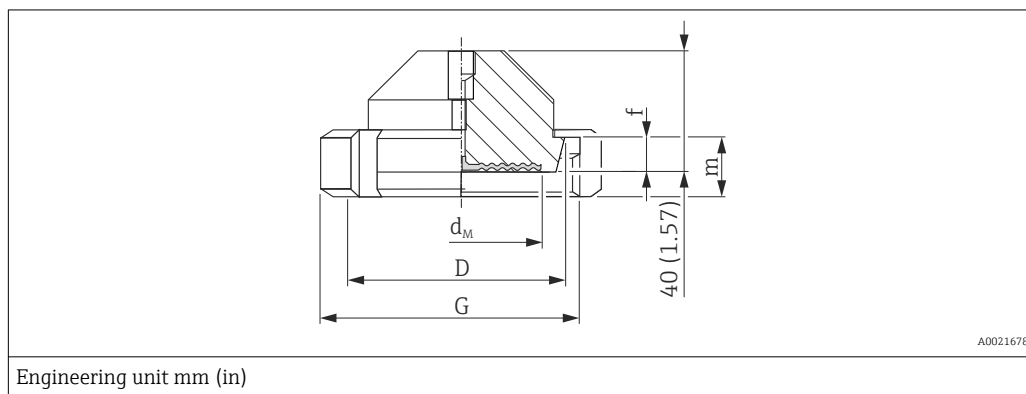

Material ¹⁾	Taper adapter				Slotted nut		Diaphragm seal			Approval	Option ²⁾
							Max. diameter of the process isolating diaphragm		Weight		
	Description	Nominal pressure	D	Nozzle height	Thread	Height	Standard	with TempC membrane			
		PN		f			G	m	d _M		
	[bar]	[mm]	[mm]		[mm]	[mm]	[mm]				
AISI 316L	DN 32	PN 40	50	10	Rd 58 x 1/6"	21	32	28	0.45 (0.99)	3A, EHEDG	MI ³⁾
	DN 40	PN 40	56	10	Rd 65 x 1/6"	21	38	36	0.45 (0.99)	3A, EHEDG	MZ ³⁾
	DN 50	PN 25	68.5	11	Rd 78 x 1/6"	19	52	48	1.1 (2.43)	3A, EHEDG	MR ⁴⁾
	DN 65	PN 25	86	12	Rd 95 x 1/6"	21	66	61	2.0 (4.41)	3A, EHEDG	MS ⁴⁾
	DN 80	PN 25	100	12	Rd 110 x 1/4"	26	81	61	2.55 (5.62)	3A, EHEDG	MT ⁴⁾

1) Surface roughness of the wetted surfaces $R_a < 0.76 \mu\text{m}$ (29.9 μin) as standard.

2) Product Configurator, order code for "Process connection"

3) With TempC diaphragm

4) Alternatively available with TempC membrane.

NEUMO BioControl

Process temperature range: -10 to +200 °C (+14 to +392 °F)

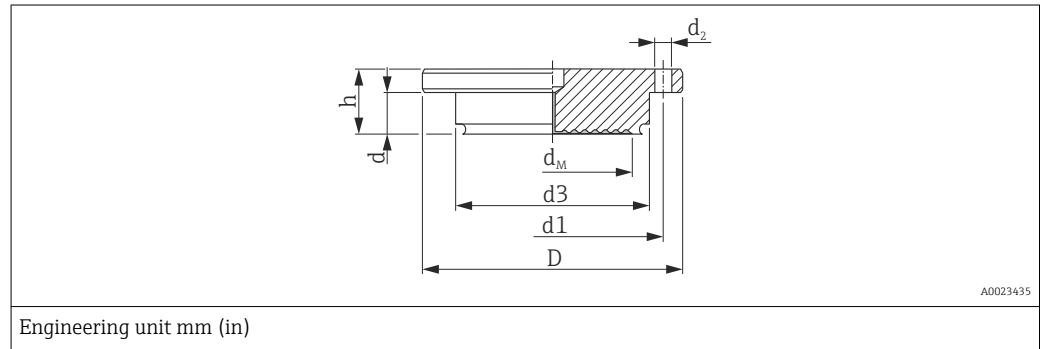

Material ¹⁾	NEUMO BioControl								Diaphragm seal			Approval	Option ²⁾
									Max. diameter of the process isolating diaphragm		Weight		
	Nominal of the diaphragm	Nominal pressure PN [bar]	Diameter					Height m	Standard	with TempC membrane			
			D [mm]	d [mm]	d ₂ [mm]	d ₃ [mm]	d ₁ [mm]		d _M [mm]	d _M [mm]	[kg (lb)]		
AISI 316L	DN 50	PN 16	90	17	4 x Ø 9	50	70	27	40	36	1.1 (2.43)	3A	S4 ³⁾
	DN 80	PN 16	140	25	4 x Ø 11	87.4	115	37	61	61	2.6 (5.73)	3A	S6 ³⁾

- 1) Surface roughness of the wetted surfaces $R_a < 0.76 \mu\text{m}$ (29.9 μin) as standard.
- 2) Product Configurator, order code for "Process connection"
- 3) With TempC membrane

Universal process adapter

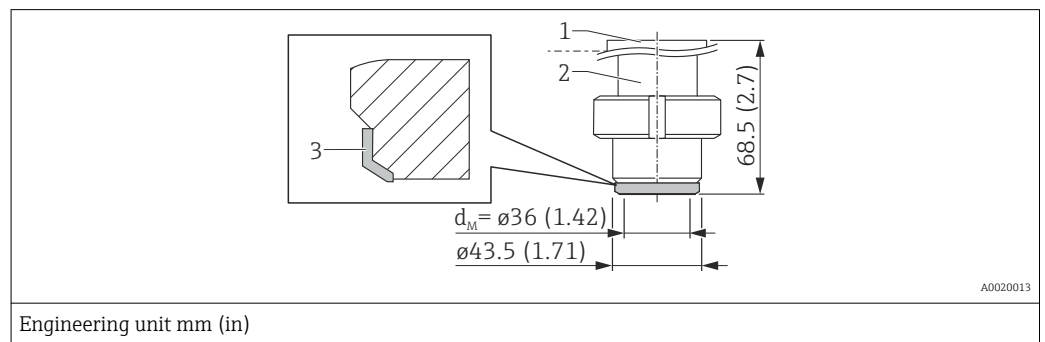

Description	Material ¹⁾	Weight	Approval	Option ²⁾
		[kg (lb)]		
Universal process adapter with pre-installed silicone molded seal (item 3) (spare part no.: 52023572) FDA 21CFR177.2600/USP Class VI-70C	<ul style="list-style-type: none"> ▪ Item 1: Top section AISI 316L (1.4404) ▪ Item 2: Bottom section AISI 316L (1.4435) 	0.8 (1.76)	3A, EHEDG	00 ^{3) 4)}

- 1) Surface roughness of the wetted surfaces $R_a < 0.76 \mu\text{m}$ (29.9 μin) as standard. Surface quality $R_a < 0.38 \mu\text{m}$ (15 μin) electropolished (wetted)
Ordering information: Product Configurator, order code for "Additional options 2", option "P".
- 2) Product Configurator, order code for "Process connection"
- 3) Endress+Hauser supplies these slotted nuts in stainless steel AISI 304 (DIN/EN material number 1.4301) or in AISI 304L (DIN/EN material number 1.4307).
- 4) Alternatively available with TempC membrane.

Process connections for PMP75 with flush-mounted process isolating diaphragm

EN/DIN flanges, connection dimensions in accordance with EN 1092-1/DIN 2527 and DIN 2501-1

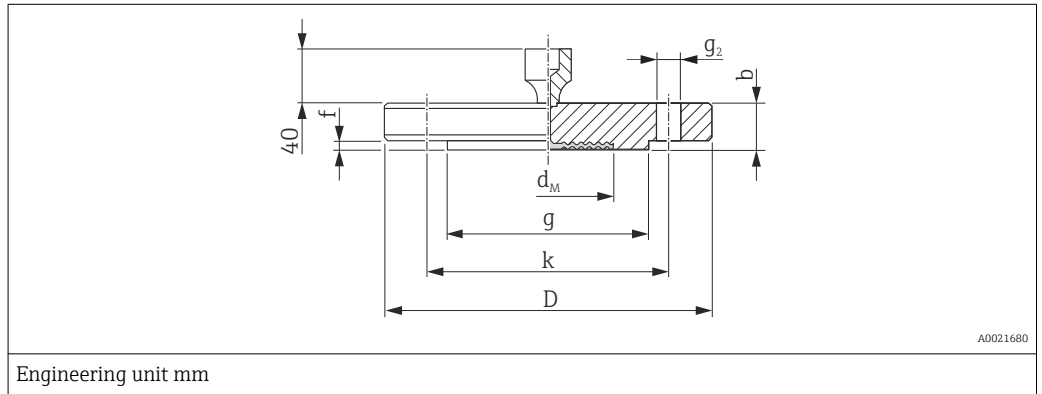

Flange ^{1) 2) 3)}							Boltholes			Diaphragm seal		Option ⁴⁾
Nominal diameter	Nominal pressure	Shape ⁵⁾	D	Thickness	Raised face		Number	g ₂	Hole circle	max. diameter process isolating diaphragm	Weight	
				b	g	f			k			
				[mm]	[mm]	[mm]			[mm]			
DN 25	PN 10-40	B1 (D)	115	18	68	3	4	14	85	32	2.1 (4.63)	CN
DN 25	PN 63-160	B2 (E)	140	24	68	2	4	18	100	28	2.5 (5.51)	DN
DN 25	PN 250	B2 (E)	150	28	68	2	4	22	105	28	3.7 (8.16)	EN
DN 25	PN 400	B2 (E)	180	38	68	2	4	26	130	28	7.0 (15.44)	E1
DN 32	PN 10-40	B1 (D)	140	18	77	2.6	4	18	100	34	1.9 (4.19)	CP
DN 40	PN 10-40	B1 (D)	150	18	87	2.6	4	18	110	48	2.2 (4.85)	CQ
DN 50	PN 10-40	B1 (D)	165	20	102	3	4	18	125	59	3.0 (6.62)	B3
DN 50	PN 63	B2 (E)	180	26	102	3	4	22	135	59	4.6 (10.14)	C3
DN 50	PN 100-160	B2 (E)	195	30	102	3	4	26	145	59	6.2 (13.67)	EF
DN 50	PN 250	B2 (E)	200	38	102	3	8	26	150	59	7.7 (16.98)	ER
DN 50	PN 400	B2 (E)	235	52	102	3	8	30	180	59	14.7 (32.41)	E3
DN 80	PN 10-40	B1 (D)	200	24	138	3.5	8	18	160	89	5.3 (11.69)	B4
DN 80	PN 100	B2 (E)	230	32	138	4	8	24	180	89	8.9 (19.62)	C4
DN 100	PN 100	B2 (E)	265	36	175	5	8	30	210	89	13.7 (30.21)	C5

- 1) material: AISI 316L
- 2) The roughness of the surface in contact with the medium including the raised face of the flanges (all standards) made of Alloy C276, Monel, tantalum, rhodium-gold or PTFE is $R_a < 0.8 \mu\text{m}$ (31.5 μin). Reduced surface roughness on request.
- 3) The raised face of the flange is made of the same material as the process isolating diaphragm.
- 4) Product Configurator, order code for "Process connection"
- 5) Description as per DIN 2527 provided in brackets

EN/DIN flanges with barrel (extended diaphragm seal), connection dimensions in accordance with EN 1092-1/DIN 2527 and DIN 2501-1

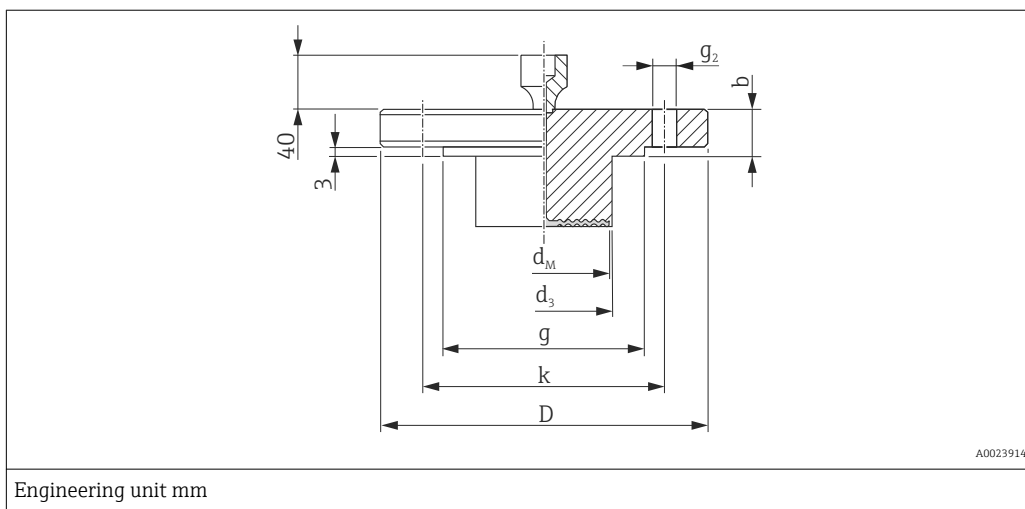

Flange ^{1) 2)}						Boltholes			Diaphragm seal		Option ³⁾
Nominal diameter	Nominal pressure	Shape ⁴⁾	D	Thickness	Raised face	Number	g ₂	Hole circle	max. diameter of the process isolating diaphragm	Weight	
				b	g			k			
			[mm]	[mm]	[mm]			[mm]			
DN 50	PN 10-40	B1 (D)	165	20	102	4	18	125	47	⁵⁾	D3 ⁵⁾
DN 80	PN 10-40	B1 (D)	200	24	138	8	18	160	72	⁵⁾	D4 ⁵⁾

- 1) Material: AISI 316L
- 2) In the case of process isolating diaphragms made of Alloy C276, Monel or tantalum, the raised face of the flange and the barrel pipe are made of 316L
- 3) Product Configurator, order code for "Process connection"
- 4) Description as per DIN 2527 provided in brackets
- 5) Available with 50 mm (1.97 in), 100 mm (3.94 in) and 200 mm (7.87 in) barrel, (extended diaphragm seal), for barrel (extended diaphragm seal) diameter and weight see the following table

Option ¹⁾	Nominal diameter	Nominal pressure	Barrel (extended diaphragm seal) length		Barrel (extended diaphragm seal) diameter	Weight
			(L)		d ₃	
			[mm]		[mm]	
D3	DN 50	PN 10-40	50 / 100 / 200		48.3	3.2 (7.1) / 3.8 (8.4) / 4.4 (9.7)
D4	DN 80	PN 10-40	50 / 100 / 200		76	6.2 (13.7) / 6.7 (14.8) / 7.8 (17.2)

- 1) Product Configurator, order code for "Process connection"

Process connections for PMP75 with flush-mounted process isolating diaphragm

ASME flanges, in accordance with connection dimensions ASME B 16.5, raised face RF

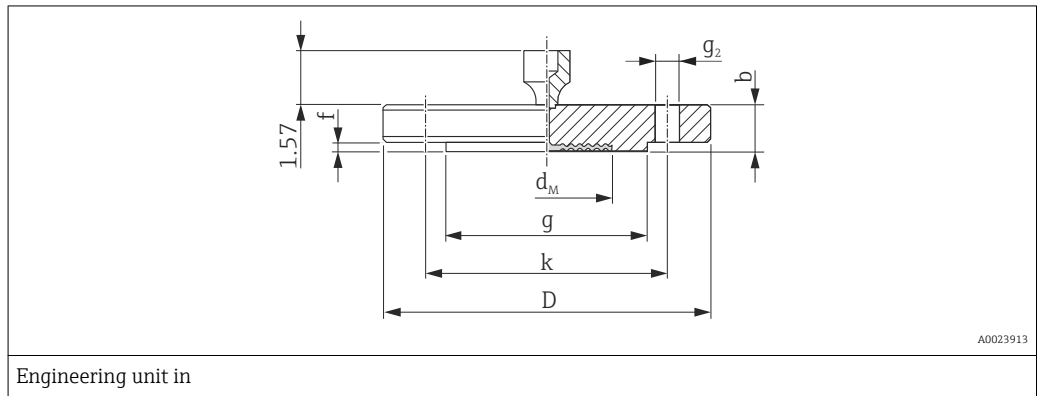

Flange ^{1) 2) 3)}						Boltholes			Diaphragm seal		Approval ⁴⁾	Option ⁵⁾
Nominal diameter	Class	D	Thickness			Number	g ₂	Hole circle	max. diameter of the process isolating diaphragm	Weight		
			b	g	f							
[in]	[lb./sq.in]	[in]	[in]	[in]	[in]		[in]	[in]	[in]	[kg (lb)]		
1	150	4.25	0.56	2	0.08	4	0.62	3.12	1.26	1.2 (2.65)	CRN	AC
1	300	4.88	0.69	2	0.08	4	0.75	3.5	1.26	1.3 (2.87)	CRN	AN
1	400/600	4.88	0.69	2	0.25	4	0.75	3.5	1.26	1.4 (3.09)	CRN	HC
1	900/1500	5.88	1.12	2	0.25	4	1	4	1.26	3.2 (7.06)	CRN	HN
1	2500	6.25	1.38	2	0.25	4	1	4.25	1.26	4.6 (10.14)	CRN	HO
1 ½	150	5	0.69	2.88	0.06	4	0.62	3.88	1.89	1.5 (3.31)	CRN	AE
1 ½	300	6.12	0.81	2.88	0.06	4	0.88	4.5	1.89	2.6 (5.73)	CRN	AQ
2	150	6	0.75	3.62	0.06	4	0.75	4.75	2.32	2.2 (4.85)	CRN	AF
2	300	6.5	0.88	3.62	0.06	8	0.75	5	2.32	3.4 (7.5)	CRN	AR
2	400/600	6.5	1	3.62	0.25	8	0.75	5	2.32	4.3 (9.48)	CRN	HF
2	900/1500	8.5	1.5	3.62	0.25	8	1	6.5	2.32	10.3 (22.71)	CRN	HR
2	2500	9.25	2	3.62	0.25	8	1.12	6.75	2.32	15.8 (34.84)	-	H3
3	150	7.5	0.94	5	0.06	4	0.75	6	3.5	5.1 (11.25)	CRN	AG
3	300	8.25	1.12	5	0.06	8	0.75	6	3.5	7.0 (15.44)	CRN	AS
4	150	9	0.94	6.19	0.06	8	0.75	7.5	3.5	7.2 (15.88)	CRN	AH
4	300	10	1.25	6.19	0.06	8	0.88	7.88	3.5	11.7 (25.8)	CRN	AT

- 1) Material AISI 316/316L: Combination of AISI 316 for required pressure resistance and AISI 316L for required chemical resistance (dual rated)
- 2) The roughness of the surface in contact with the medium including the raised face of the flanges (all standards) made of Alloy C276, Monel, tantalum, rhodium-gold or PTFE is R_a < 0.8 μm (31.5 μin). Lower surface roughness on request.
- 3) The flange raised face is made of the same material as the process isolating diaphragm.
- 4) CSA approval: Product Configurator, order code for "Approval"
- 5) Product Configurator, order code for "Process connection"

ASME flanges with barrel (extended diaphragm seal), connection dimensions in accordance with ASME B 16.5, raised face RF

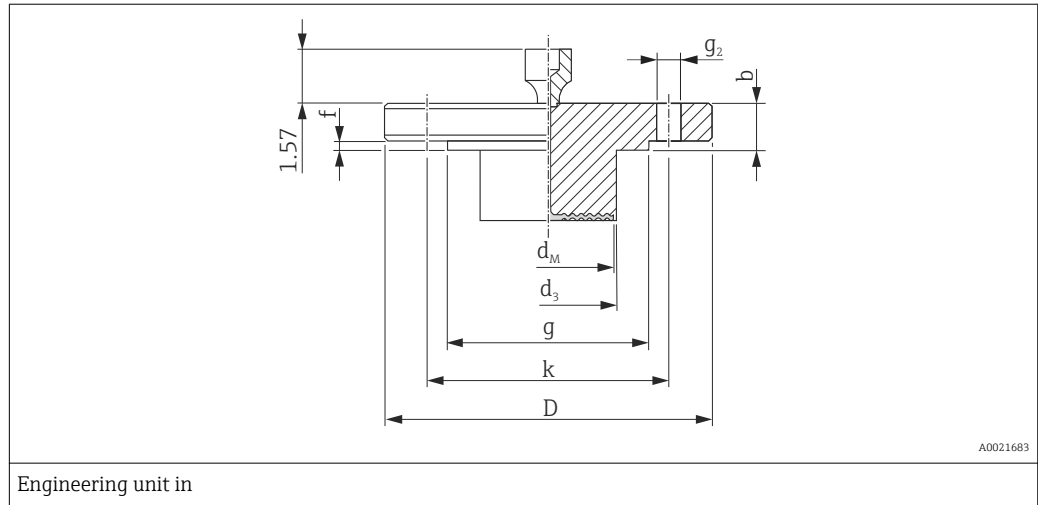

Flange ^{1) 2)}						Boltholes			Diaphragm seal		Approval ³⁾	Option ⁴⁾	
Nominal diameter	Class	D	Thickness		Raised face	Number	g ₂	Hole circle		max. Ø membrane			Weight
			b	g				f	k	d _M			
[in]	[lb./sq.in]	[in]	[in]	[in]	[in]		[in]	[in]	[in]	[kg (lb)]			
2	150	6	0.75	3.62	0.06	4	0.75	4.75	1.85	⁵⁾	CRN	J3 ⁵⁾	
3	150	7.5	0.94	5	0.06	4	0.75	6	2.83	⁵⁾	CRN	J4 ⁵⁾	
3	300	8.25	1.12	5	0.06	8	0.88	6.62	2.83	⁵⁾	CRN	J7 ⁵⁾	
4	150	9	0.94	6.19	0.06	8	0.75	7.5	3.5	⁵⁾	CRN	J5 ⁵⁾	
4	300	10	1.25	6.19	0.06	8	0.88	7.88	3.5	⁵⁾	CRN	J8 ⁵⁾	

- 1) Material: AISI 316/316L. Combination of AISI 316 for required pressure resistance and AISI 316L for required chemical resistance (dual rated)
- 2) In the case of process isolating diaphragms made of Alloy C276, Monel or tantalum, the raised face of the flange and the barrel pipe are made of 316L.
- 3) CSA approval: Product Configurator, order code for "Approval"
- 4) Product Configurator, order code for "Process connection"
- 5) Choice of 2", 4", 6" or 8" barrel (extended diaphragm seal), for diameter and weight of barrel (extended diaphragm seal) see the following table

Option ¹⁾	Nominal diaphragm	Class	Barrel (extended diaphragm seal) length		Barrel (extended diaphragm seal) process isolating diaphragm	Weight
			(L)	d ₃		
	[in]	[lb./sq.in]	in (mm)	in (mm)	[kg (lb)]	
J3	2	150	2 (50.8) / 4 (101.6) / 6 (152.4) / 8 (203.2)	1.9 (48.3)	3.0 (6.6) / 3.4 (7.5) / 3.9 (8.6) / 4.4 (9.7)	
J4	3	150	2 (50.8) / 4 (101.6) / 6 (152.4) / 8 (203.2)	2.99 (76)	6.0 (13.2) / 6.6 (14.5) / 7.1 (15.7) / 7.8 (17.2)	
J7	3	300	2 (50.8) / 4 (101.6) / 6 (152.4) / 8 (203.2)	2.99 (76)	7.9 (17.4) / 8.5 (18.7) / 9.0 (19.9) / 9.6 (21.2)	
J5	4	150	2 (50.8) / 4 (101.6) / 6 (152.4) / 8 (203.2)	3.7 (94)	8.6 (19) / 9.9 (21.8) / 11.2 (24.7) / 12.4 (27.3)	
J8	4	300	2 (50.8) / 4 (101.6) / 6 (152.4) / 8 (203.2)	3.7 (94)	13.1 (28.9) / 14.4 (31.6) / 15.7 (34.6) / 16.9 (37.3)	

1) Product Configurator, order code for "Process connection"

JIS flanges, connection dimensions in accordance with JIS B 2220 BL, raised face RF

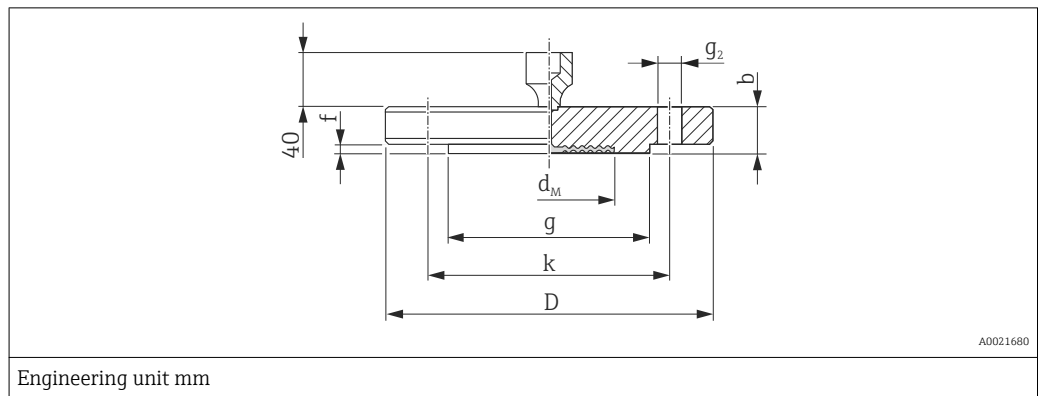

Flange ^{1) 2) 3)}						Boltholes			Diaphragm seal		Option ⁴⁾	
Nominal diameter	Nominal pressure	D	Thickness			Number	g ₂	Hole circle		max. Ø membrane		Weight
			b	g	f			k				
			[mm]	[mm]	[mm]			[mm]	[mm]	[mm]		[mm]
25 A	10 K	125	14	67	1	4	19	90	32	1.5 (3.31)	KC	
50 A	10 K	155	16	96	2	4	19	120	59	2.3 (5.07)	KF	
80 A	10 K	185	18	127	2	8	19	150	89	3.3 (7.28)	KL	
100 A	10 K	210	18	151	2	8	19	175	89	4.4 (9.7)	KH	

- 1) Material: AISI 316L
- 2) The roughness of the surface in contact with the medium including the raised face of the flanges (all standards) made of Alloy C276, Monel, tantalum, rhodium-gold or PTFE is $R_a < 0.8 \mu\text{m}$ (31.5 μin). Lower surface roughness on request.
- 3) The flange raised face is made of the same material as the process isolating diaphragm.
- 4) Product Configurator, order code for "Process connection"

Process connections for PMP75

Thread 1/2 NPT and 1 NPT, separator

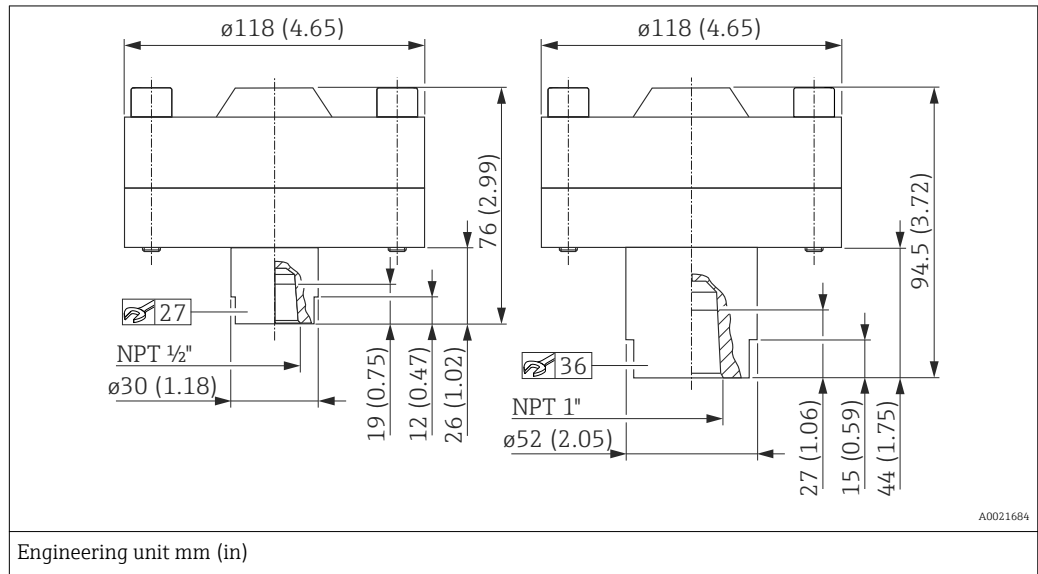

Material	Description	Measuring range	Nominal pressure	Weight	Option ¹⁾
		[bar (psi)]		[kg (lb)]	
AISI 316L	Threaded, 1/2" NPT with Viton seal (200 °C (392 °F))	≤ 250 (3625)	PN 250	4.75 (10.47)	UG
	Threaded, 1" NPT with Viton seal			5.0 (11.03)	UH

1) Product Configurator, order code for "Process connection"

Thread ISO 228 G 1/2 A and ANSI 1/2 MNPT, separator

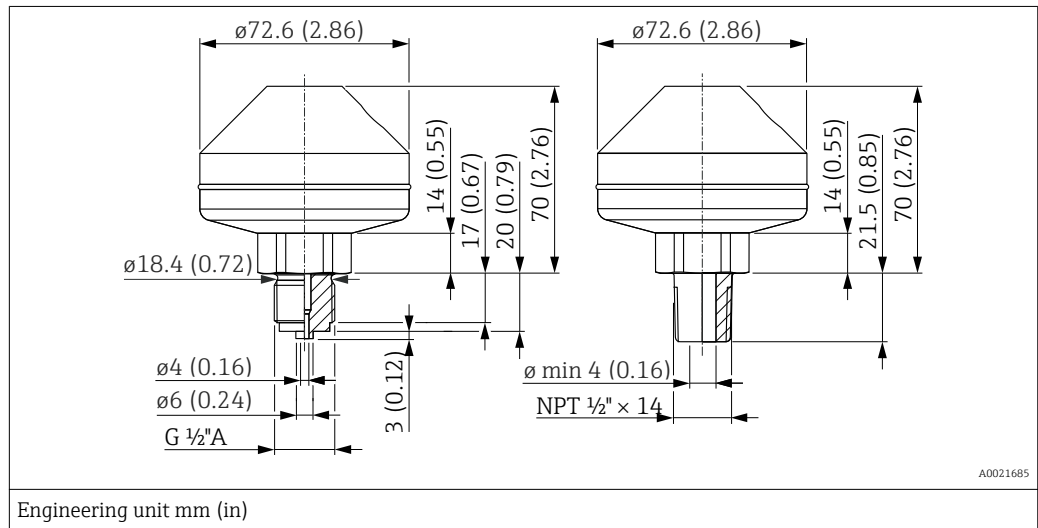

Material	Description	Measuring range	Nominal pressure	Approval	Weight	Option ¹⁾
		[bar (psi)]			[kg (lb)]	
AISI 316L	Welded, ISO 228 G 1/2 A EN837	≤ 160 (2320)	PN 160	- CRN ²⁾	1.43 (3.15)	UA
	Welded, ANSI 1/2 MNPT					UB

1) Product Configurator, order code for "Process connection"
 2) CSA approval: Product Configurator, order code for "Approval"

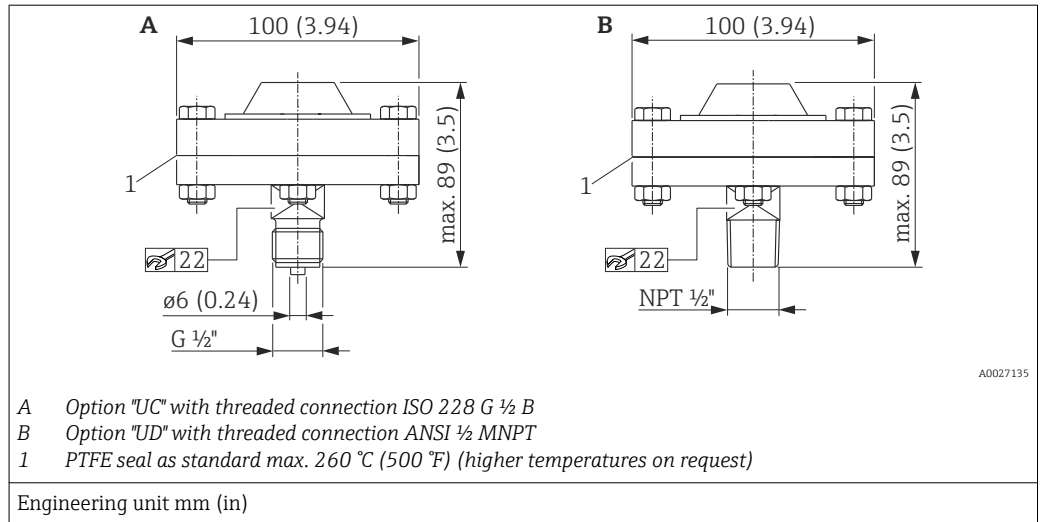

A0027135

Material	Description	Measuring range	Nominal pressure	Weight	Option ¹⁾
		[bar (psi)]		[kg (lb)]	
AISI 316L (1.4404), screws made of A2	ISO 228 G 1/2 B EN837	≤ 40 (580)	PN 40	1.43 (3.15)	UC
	ANSI 1/2 MNPT				UD

1) Product Configurator, order code for "Process connection"

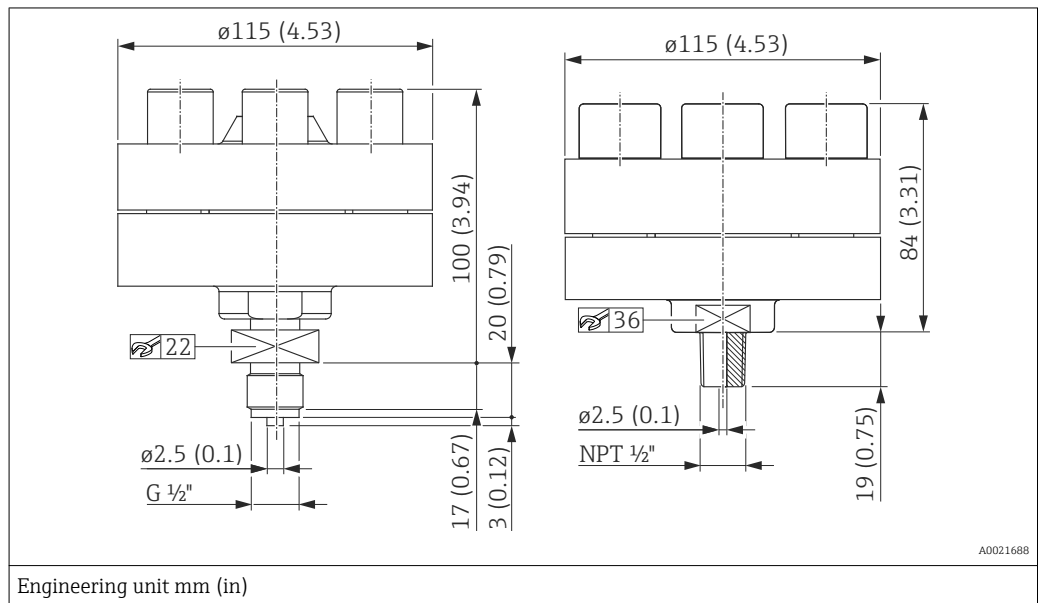

A0021688

Material	Description	Measuring range	Nominal pressure	Weight	Option ¹⁾
		[bar (psi)]		[kg (lb)]	
AISI 316L (1.4404), screws made of A2	Threaded, ISO 228 G 1/2 B EN837, with integrated seal lip	> 40 bar (580)	PN 400	4.75 (10.47)	UC
	Threaded, ANSI 1/2 MNPT, with integrated seal lip				UD

1) Product Configurator, order code for "Process connection"

Separate housing: Wall and pipe mounting with mounting bracket

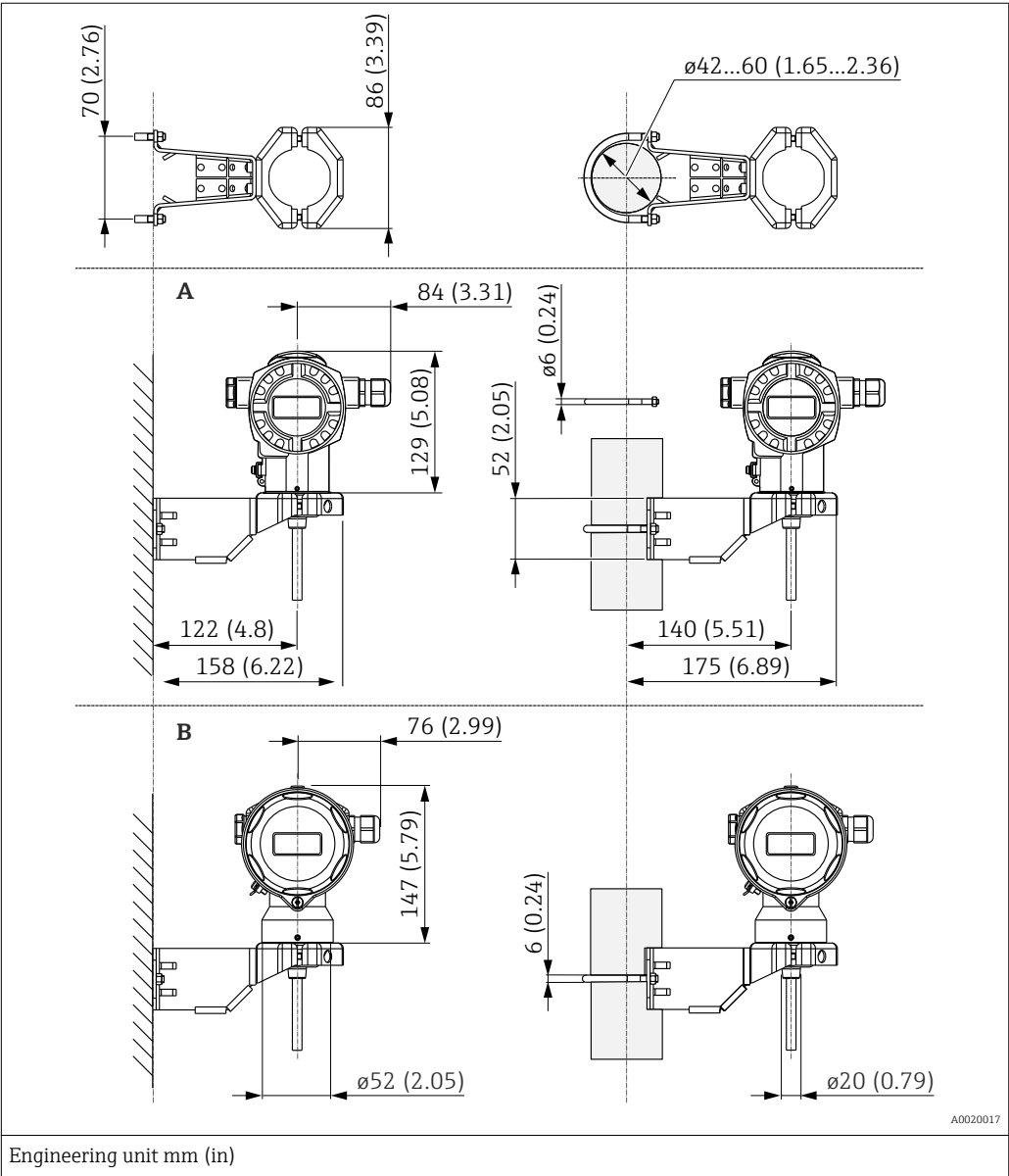

Item	Description	Weight in kg (lb)		Option ¹⁾
		Housing (T14 or T17)	Mounting bracket	
A	Dimensions with T14 housing, optional side display	→ 45	0.5 (1.10)	U
B	Dimensions with T17 housing, optional side display			

1) Product Configurator, order code for "Additional options 2", version "G"

Also available for order as a separate accessory: Part number 71102216

Materials not in contact with process Transmitter housing

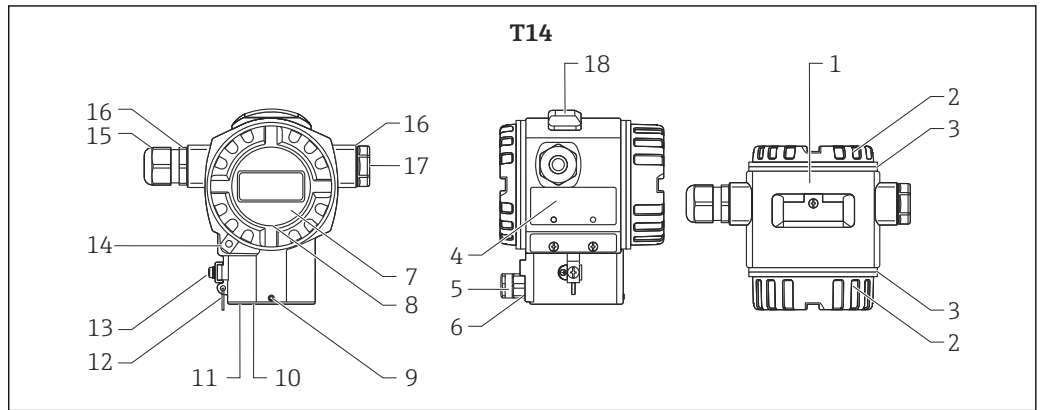

A0020019

Item number	Component part	Material
1	T14 housing, RAL 5012 (blue)	<ul style="list-style-type: none"> Die-cast aluminum with protective powder-coating on polyester base Thread coating: Heat-curing lubricant varnish
1	T14 housing	<ul style="list-style-type: none"> Precision casting AISI 316L (1.4435) Thread coating: Heat-curing lubricant varnish
2	Cover, RAL 7035 (gray)	Die-cast aluminum with protective powder-coating on polyester base
3	Cover seal	EPDM
4	Nameplates	<ul style="list-style-type: none"> AISI 316L (1.4404), if T14 housing is precision-cast Anodized aluminum, if housing T14/T15 of die-cast aluminum
5	Pressure compensation filter	AISI 316L (1.4404) and PBT-FR
6	Pressure compensation filter, O-ring	VMQ or EPDM
7	Sight glass	Mineral glass
8	Sight glass seal	Silicone (VMQ)
9	Screw	A4
10	Sealing ring	EPDM
11	Snap ring	PA66-GF25
12	Snap ring for nameplates	AISI 304 (1.4301)/AISI 316 (1.4401)
13	External ground terminal	AISI 304 (1.4301)
14	Cover clamp	Clamp AISI 316L (1.4435), screw A4
15	Cable entry	Polyamide (PA) or CuZn nickel-plated
16	Seal of cable entry and plug	Silicone (VMQ)
17	Blind plug	PBT-GF30 FR, for dust ignition-proof: AISI 316L (1.4435)
18	External operation (keys and key cover), RAL 7035 (gray)	Polycarbonate PC-FR, screw A4
Devices with MID parts certificate	Seal wire	DIN 1367-0 St/Zn (soft galvanized steel)
Devices with MID parts certificate	Seals	Pb (lead)

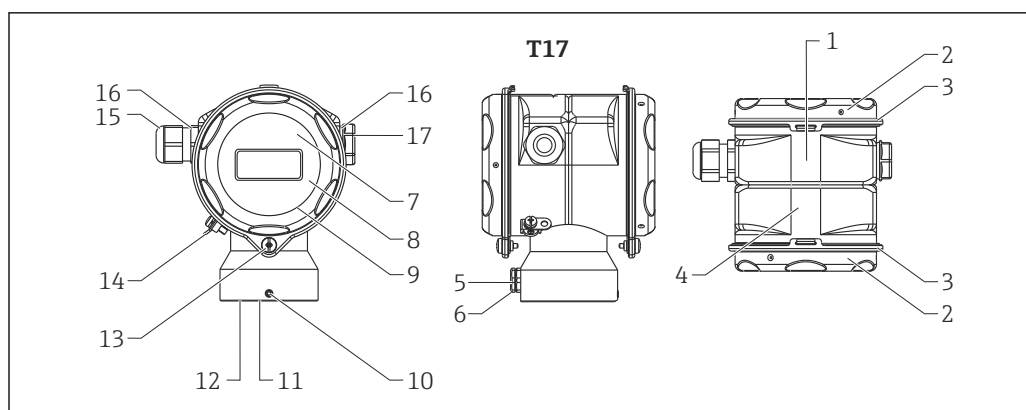

A0020021

Item number	Component part	Material
1	T17 housing	AISI 316L (1.4404)
2	Cover	AISI 316L (1.4404)
3	Cover seal	EPDM
4	Nameplates	Lasered on
5	Pressure compensation filter	AISI 316L (1.4404) and PBT-FR
6	Pressure compensation filter, O-ring	VMQ or EPDM
7	Sight glass for non-hazardous area, ATEX Ex ia, NEPSI Zone 0/1 Ex ia, IECEx Zone 0/1 Ex ia, FM NI, FM IS, CSA IS	Polycarbonate (PC)
8	Sight glass for ATEX 1/2 D, ATEX 1/3 D, ATEX 1 GD, ATEX 1/2 GD, ATEX 3 G, FM DIP, CSA dust ignition-proof	Mineral glass
9	Sight glass seal	EPDM
10	Screw	A2-70
11	Sealing ring	EPDM
12	Snap ring	PA6
13	Screw	A4-50 Thread coating: Heat-curing lubricant varnish
14	External ground terminal	AISI 304 (1.4301)
15	Cable entry	Polyamide PA, for dust ignition-proof: CuZn nickel-plated
16	Seal of cable entry and plug	Silicone (VMQ)
17	Blind plug	PBT-GF30 FR, for dust ignition-proof: AISI 316L (1.4435)
Devices with MID parts certificate	Seal wire	DIN 1367-0 St/Zn (soft galvanized steel)
Devices with MID parts certificate	Seals	Pb (lead)

Connecting parts

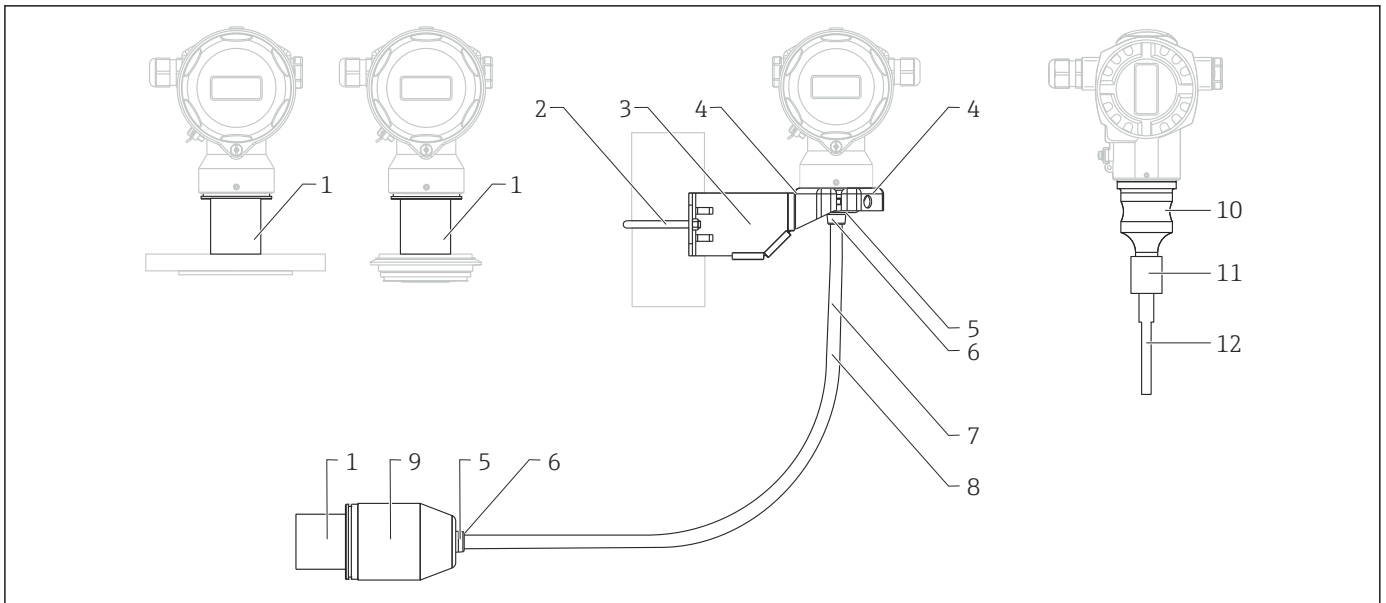

A0028222

Item number	Component part	Material
1	Connection between the housing and process connection	AISI 316L (1.4404)
2	Mounting bracket	Bracket AISI 316L (1.4404)
3		Screw and nuts A4-70
4		Half-shells: AISI 316L (1.4404)
5	Seal for cable from separate housing	EPDM
6	Gland for cable from separate housing	AISI 316L (1.4404)
7	PE cable for separate housing	abrasion-proof cable with strain-relief Dynema members; shielded using aluminum-coated foil; insulated with polyethylene (PE-LD), black; copper wires, twisted, UV-resistant
8	FEP cable for separate housing	Abrasion-proof cable; shielded using galvanized steel wire netting; insulated with fluorinated ethylene propylene (FEP), black; copper cores, twisted, UV-resistant
9	Process connection adapter for separate housing	AISI 316L (1.4404)
10	Cell body	AISI 316L (1.4404)
11	Connection between body of measuring cell and capillary	AISI 316L (1.4404)
12	Heat-shrink tube (available only if capillary has PTFE or PVC sheath)	Polyolefin

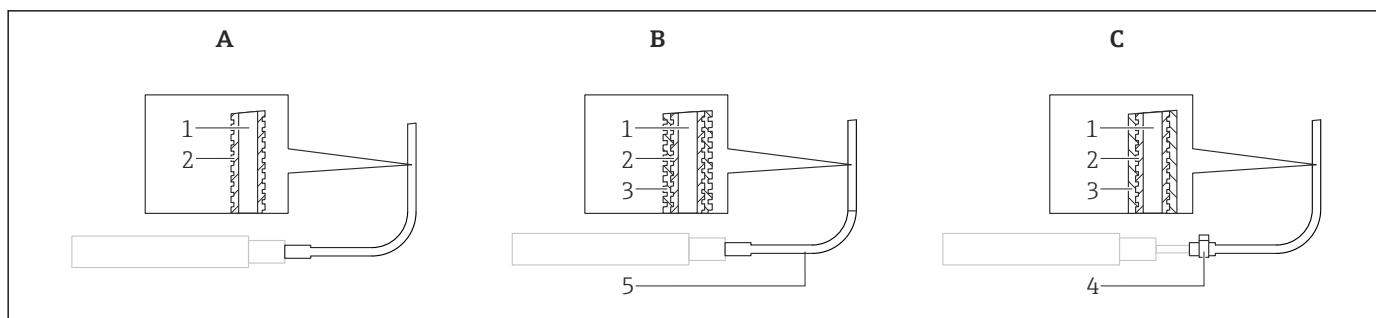

A0028087

Item	Component part	A Standard flexible capillary armoring	B PVC-coated flexible capillary armoring	C PTFE-hose flexible capillary armoring
1	Capillary	AISI 316 Ti (1.4571) ¹⁾	AISI 316 Ti (1.4571)	AISI 316 Ti (1.4571)
2	Flexible armor for capillary	AISI 316L (1.4404)	AISI 316L (1.4404)	AISI 316L (1.4404)
3	Coating/Hose	-	PVC ²⁾	PTFE ³⁾
4	Single-ear clamp	-	-	1.4301
5	Shrink tubing at capillary junction	-	Polyolefin	-

- 1) Product Configurator, order code for "Capillary armoring:" option "SA"
- 2) Product Configurator, order code for "Capillary armoring:" option "SB"
- 3) Product Configurator, order code for "Capillary armoring:" option "SC"

Weight	Component part	Weight
	Housing	See "Housing" section
	Process connection	See "Process connections" section
	Capillary with armoring made of AISI 316L (1.4404)	0.16 kg/m (0.35 lb/m) + 0.35 kg (0.77 lb)
	Capillary with armoring made of AISI 316L (PVC)	0.21 kg/m (0.46 lb/m) + 0.35 kg (0.77 lb)
	Capillary with armoring made of AISI 316L (PTFE)	0.29 kg/m (0.64 lb/m) + 0.35 kg (0.77 lb)

Materials in contact with process

NOTICE

- ▶ The device components in contact with the process are specified in the "Mechanical construction" → 44 and "Ordering information" → 109 sections.

Delta-ferrite content

A delta-ferrite content of ≤ 3% can be guaranteed and certified for the wetted parts if option "8" is selected in the "Additional options 1" or "Additional options 2" order code in the Product Configurator.

If the PMC71 with hygienic process connections is selected, a delta-ferrite content of ≤ 1% can be guaranteed and certified if option "8" is selected in the "Additional options 1" or "Additional options 2" order code in the Product Configurator.

TSE Certificate of Suitability (Transmissible Spongiform Encephalopathy)

The following applies to all device components in contact with the process:

- They do not contain any materials derived from animals.
- No additives or operating materials derived from animals are used in production or processing.

Process connections

- "Clamp connections" and "Hygienic process connections": AISI 316L (DIN/EN material number 1.4435)
- Endress+Hauser supplies process connections with a threaded connection as well as DIN/ EN flanges made of stainless steel as per AISI 316L (DIN/EN material number 1.4404 or 1.4435). With regard to their stability-temperature property, the materials 1.4404 and 1.4435 are grouped together under 13EO in EN 1092-1: 2001 Tab. 18. The chemical composition of the two materials can be identical.
- Some process connections are also available in alloy C276 (DIN/EN material number 2.4819). For this purpose see the information in the "Mechanical construction" section.

Process isolating diaphragm

Sensor	Description	Option ¹⁾
PMC71	Al ₂ O ₃ aluminum-oxide ceramic FDA, ultra-pure 99.9 % ²⁾ Ceraphire® (see also www.endress.com/ceraphire)	Standard
PMP71	AISI 316L	1
	AISI 316L with gold-rhodium coating	6
	Alloy C276 (2.4819)	2
PMP75	AISI 316L	1
	AISI 316L, TempC	E
	AISI 316L with gold-rhodium coating	6
	AISI 316L with 0.25 mm (0.01 in)PTFE coating	8
	Alloy C276 (2.4819)	2 ³⁾
	Monel (2.4360)	3 ³⁾
	Tantalum (UNS R05200)	5 ³⁾

- 1) Product Configurator, order code for "Membrane material"
- 2) The US Food & Drug Administration (FDA) has no objections to the use of ceramics made of aluminum oxide as a surface material in contact with foodstuffs. This declaration is based on the FDA certificates of our ceramic suppliers
- 3) The material of the flange raised face is the same material as is used for the process isolating diaphragm. For devices with a barrel (extended diaphragm seal), the flange raised face and the barrel pipe are made of 316L.

Seals

Device	Description	Option ¹⁾
PMC71	FKM Viton	A
	FKM Viton, FDA	G
	EPDM	B
	Kalrez	D
	Chemraz	E
	NBR (FDA)/3A: HNBR (FDA)	F
	FKM Viton, cleaned for silicone-free applications	L
	Kalrez, cleaned for silicone-free applications	M
	FKM Viton, cleaned from oil and grease	1
	FKM Viton, cleaned for oxygen service, note pressure and temperature application limits	2

- 1) Product Configurator, order code for "Seal"

Fill fluid**PMP71**

Description	Option ¹⁾
Silicone oil	A
Inert oil	F
Inert oil, cleaned from oil and grease	K
Inert oil, cleaned for oxygen service (observe application limits pressure/temperature)	N

1) Product Configurator, order code for "Fill fluid"

PMP75

Description	Option ¹⁾
Silicone oil	A
...m capillary, inert oil	B
...ft capillary, inert oil	C
Vegetable oil	D
Inert oil	F
High-temperature oil, temperature isolator	G
Silicon oil, temperature isolator	H
Inert oil, cleaned from oil and grease	K
Inert oil, cleaned for oxygen service	N
...m capillary, silicone oil	1
...ft capillary, silicone oil	2
...m capillary, high-temperature oil	3
...ft capillary, high-temperature oil	4
...m capillary, vegetable oil	5
...ft capillary, vegetable oil	6
...m capillary, low-temperature oil	7
...ft capillary, low-temperature oil	8

1) Product Configurator, order code for "Fill fluid"

Operability

Operating concept

Operator-oriented menu structure for user-specific tasks

- Commissioning
- Operation
- Diagnosis

Fast and safe commissioning

Guided menus for applications

Reliable operation

- Local operation possible in several languages
- Standardized operation at the device and in the operating tools
- Parameters relating to measured values can be locked/unlocked using the device's write protection switch, using the device software or via remote operation

Efficient diagnostics increase measurement availability

- Remedial measures are integrated in plain text
- Diverse simulation options

Local operation

Functions

Function	External operation (operating keys, optional, not T17 housing)	Internal operation (electronic insert)	Onsite display (optional)
Position adjustment (zero point correction)	✓	✓	✓
Setting lower-range value and upper-range value - reference pressure present at the device	✓ (HART only)	✓ (HART only)	✓
Device reset	✓	✓	✓
Locking and unlocking parameters relevant to the measured value	—	✓	✓
Value acceptance indicated by green LED	✓	✓	✓
Switching damping on and off	✓ (only if display is connected)	✓ (HART and PA only)	✓
Configuring the bus address of the device (PA)	—	✓	✓
Switching simulation mode on and off (FOUNDATION Fieldbus)	—	✓	✓

Operating the device using onsite display (optional)

A 4-line liquid crystal display (LCD) is used for display and operation. The onsite display shows measured values, dialog text as well as fault and notice messages in plain text, thereby supporting the user in every stage of operation.

The display can be removed for easy operation.

The device display can be turned in 90° steps.

Depending on the installation position of the device, this makes it easy to operate the device and read the measured value.

Functions:

- 8-digit measured value display incl. leading sign and decimal point, bar graph for
 - 4 to 20 mA HART as current display
 - PROFIBUS PA as graphic display of the standardized value of the AI block
 - FOUNDATION Fieldbus as graphic display of the transducer output.
- Simple and complete menu guidance due to breakdown of parameters into several levels and groups
- Menu guidance in up to 8 languages
- Each parameter is given a 3-digit ID number for easy navigation.
- Option for configuring the display according to individual requirements and preferences, such as language, alternating display, display of other measured values such as sensor temperature, contrast setting.
- Comprehensive diagnostic functions (fault and warning message, peak-hold indicators, etc.).
- Rapid and safe commissioning with the Quick Setup menus.

Overview

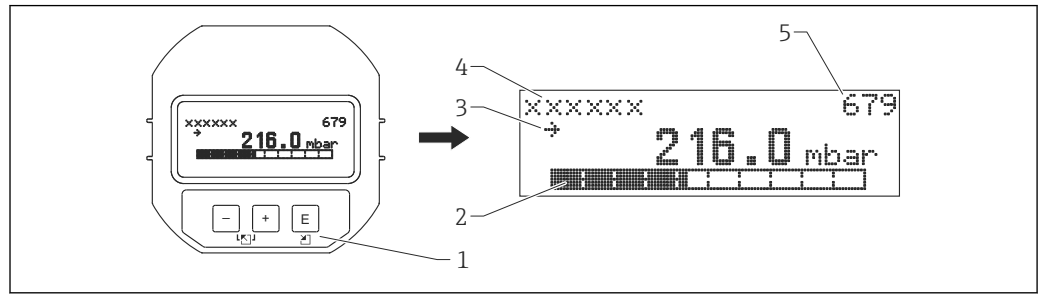

A0016498

- 1 Operating keys
- 2 Bargraph
- 3 Symbol
- 4 Header
- 5 Parameter ID number

Operating keys on the exterior of the device

With the aluminum housing (T14), the operating keys are located either outside on the housing, under the protection cap or inside on the electronic insert. With the stainless steel housing (T17), the operating keys are always located inside the housing on the electronic insert.

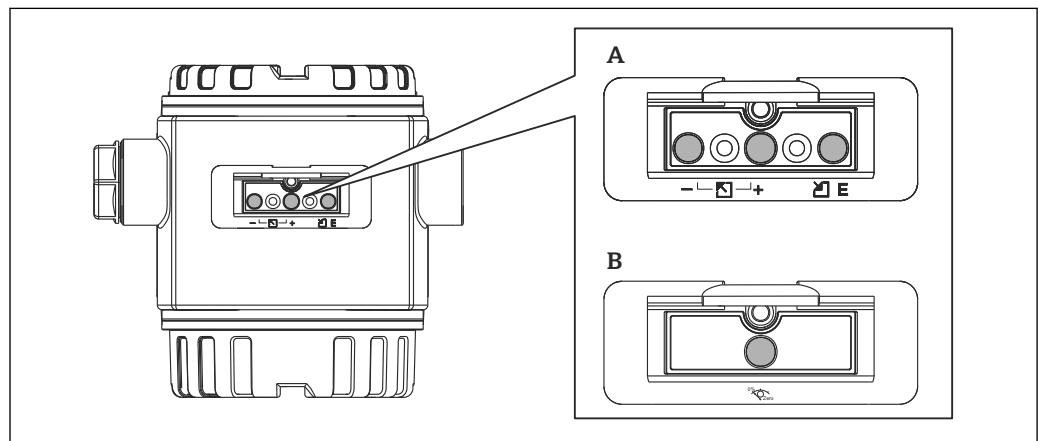

A0020030

- A 4 to 20 mA HART
- B PROFIBUS PA and FOUNDATION Fieldbus

The operating keys located externally on the device work on the Hall sensor principle. As a result, no additional openings are required in the device. This guarantees:

- Complete protection against environmental influences such as moisture and contamination.
- Simple operation without any tools.
- No wear.

Ordering information:

Product Configurator, order code for "Output, operation"

Operating keys and elements located internally on the electronic insert

Ordering information:

Product Configurator, order code for "Output, operation"

HART

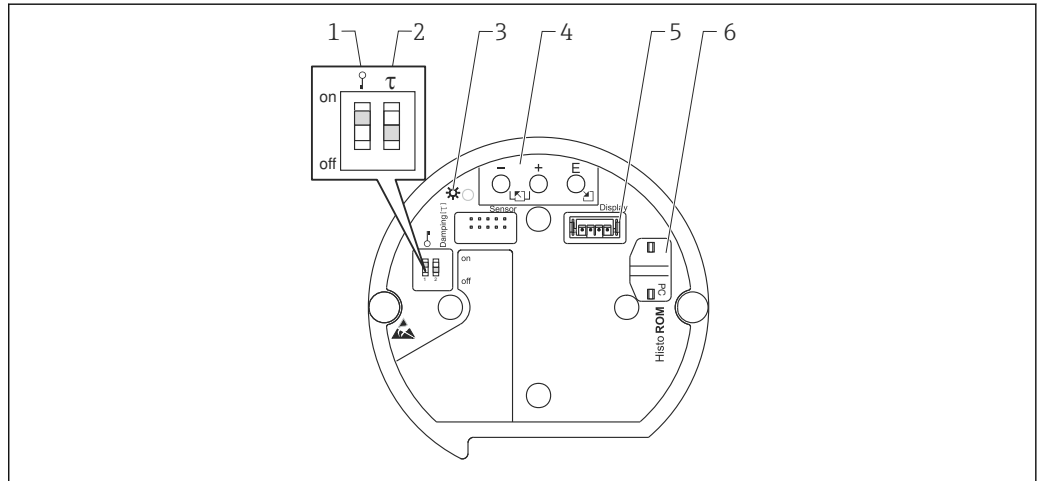

A0020031

- 1 DIP switch for locking/unlocking parameters relevant to the measured value
- 2 DIP switch for switching damping on/off
- 3 Green LED to indicate value being accepted
- 4 Operating keys
- 5 Slot for optional display
- 6 Slot for optional HistoROM®/M-DAT

PROFIBUS PA

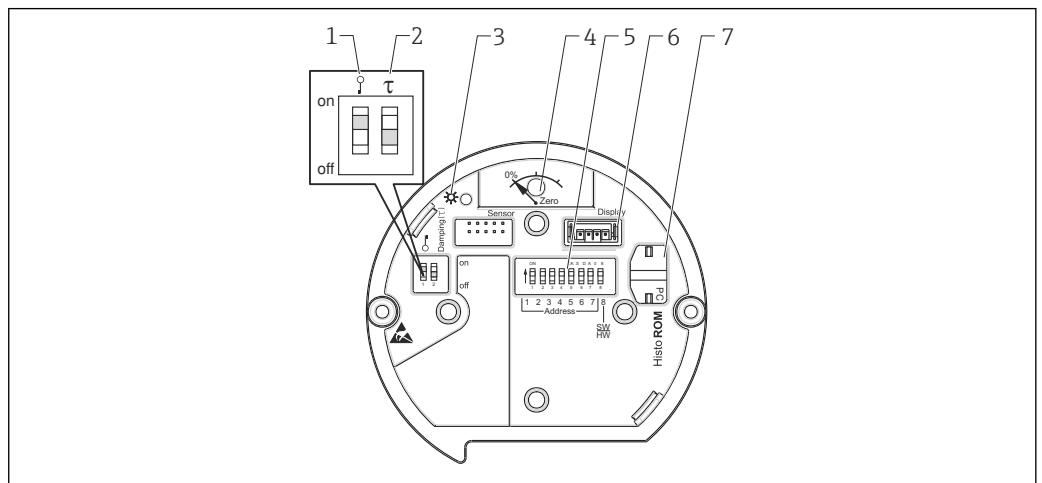

A0020032

- 1 DIP switch for locking/unlocking parameters relevant to the measured value
- 2 DIP switch for switching damping on/off
- 3 Green LED to indicate value being accepted
- 4 Key for position adjustment and device reset
- 5 DIP switch for bus address
- 6 Slot for optional display
- 7 Slot for optional HistoROM®/M-DAT

FOUNDATION Fieldbus

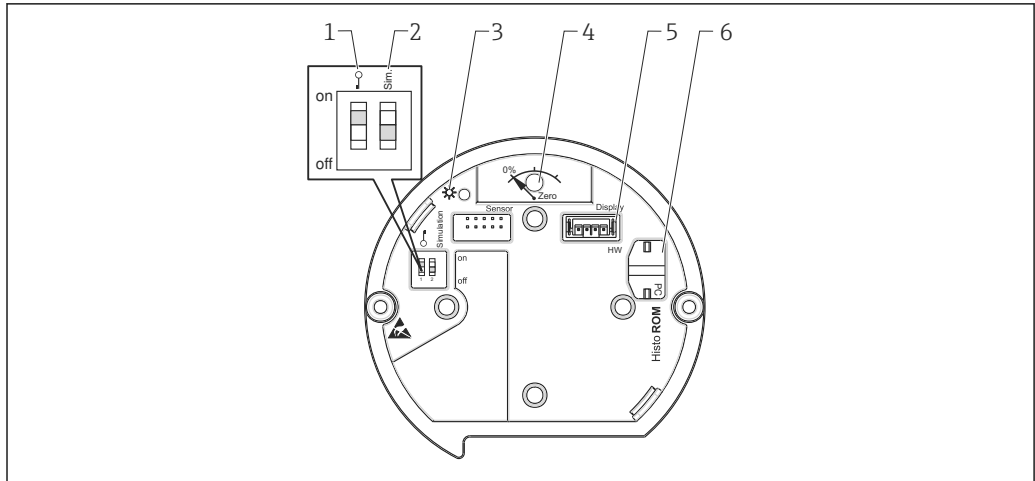

A0020033

- 1 DIP switch for locking/unlocking parameters relevant to the measured value
- 2 DIP switch for simulation mode on/off
- 3 Green LED to indicate value being accepted
- 4 Key for position adjustment and device reset
- 5 Slot for optional display
- 6 Slot for optional HistoROM®/M-DAT

Remote operation

All software parameters are accessible depending on the position of the write protection switch on the device.

Hardware and software for remote operation	HART	PROFIBUS PA	FOUNDATION Fieldbus
FieldCare	✓	✓	✓
FieldXpert SFX100	✓	—	✓
NI-FBUS Configurator	—	—	✓
HistoROM®/M-DAT	✓	✓	✓

FieldCare

FieldCare is an Endress+Hauser asset management tool based on FDT technology. With FieldCare, you can configure all Endress+Hauser devices as well as devices from other manufacturers that support the FDT standard.

FieldCare supports the following functions:

- Configuration of transmitters in offline and online mode
- Loading and saving device data (upload/download)
- HistoROM®/M-DAT analysis
- Documentation of the measuring point

Connection options:

- HART via Commubox FXA195 and the USB port on a computer
- PROFIBUS PA via segment coupler and PROFIBUS interface card
- Service interface with Commubox FXA291 and ToF adapter FXA291 (USB).

For further information please contact your local Endress+Hauser Sales Center.

Field Xpert SFX100

Field Xpert is an industrial PDA with integrated 3.5" touchscreen from Endress+Hauser based on Windows Mobile. It offers wireless communication via the optional VIATOR Bluetooth modem from Endress+Hauser. Field Xpert also works as a stand-alone device for asset management applications. For details, refer to BA00060S/04/EN.

Commubox FXA195

For intrinsically safe HART communication with FieldCare via the USB interface. For details refer to TI00404F/00/EN.

Commubox FXA291

The Commubox FXA291 connects Endress+Hauser field devices with a CDI interface (=Endress+Hauser Common Data Interface) to the USB interface of a personal computer or a notebook. For details refer to TI00405C/07/EN.



For the following Endress+Hauser devices you need the "ToF adapter FXA291" as an additional accessory:

- Cerabar S PMC71, PMP7x
- Deltabar S PMD7x, FMD7x
- Deltapilot S FMB70

ToF adapter FXA291

The ToF adapter FXA291 connects the Commubox FXA291 with devices of the ToF platform, pressure equipment and Gammapilot via the USB interface of a personal computer or a notebook. For details refer to KA00271F.

Profiboard

For connecting a PC to PROFIBUS.

Proficard

For connecting a laptop to PROFIBUS

FF configuration program

FF configuration program, such as NI-FBUS Configurator, to

- connect devices with "FOUNDATION Fieldbus signal" into an FF network
- set FF-specific parameters

Remote operation via the NI-FBUS Configurator:

The NI-FBUS Configurator is an easy-to-use graphical environment for creating linkages, field-based control loops and schedules based on the FOUNDATION Fieldbus concept.

You can use the NI-FBUS Configurator to configure a fieldbus network as follows:

- Set block and device tags
- Set device addresses
- Create and edit function block control strategies (function block applications)
- Configure vendor-defined function and transducer blocks
- Create and edit schedules
- Read and write to function block control strategies (function block applications)
- Invoke Device Description (DD) methods
- Display DD menus
- Download a configuration
- Verify a configuration and compare it to a saved configuration
- Monitor a downloaded configuration
- Replace a virtual device by a real device
- Save and print a configuration

HistoROM®/M-DAT (optional)

HistoROM®/M-DAT is a memory module which can be attached to every electronic insert. HistoROM®/M-DAT can be retrofitted at any stage (order number: 52027785).

Your benefits

- Quick and safe commissioning of the same measuring points by copying the configuration data of one transmitter to another transmitter.
- Reliable process monitoring thanks to cyclical recording of pressure and sensor temperature measured values.
- Simple diagnosis by recording diverse events such as alarms, configuration changes, counters for measuring range undershoot and overshoot for pressure and temperature as well as user limit overshoot and undershoot for pressure and temperature etc.
- Analysis and graphic evaluation of the events and process parameters via software (contained in scope of supply).

A CD with an Endress+Hauser operating program is also included in the scope of delivery. You can copy data from one transmitter to another transmitter when operating a FOUNDATION Fieldbus device via an FF configuration program. You need the Endress+Hauser FieldCare operating program and the Commubox FXA291 service interface and the ToF adapter FXA291 to be able to access the data and events saved in the HistoROM®/M-DAT.

Ordering information:

Product Configurator, order code for "Additional options:", version "N" or

Product Configurator, order code for "Application package:", option "EN" or

as a separate accessory (part no.: 52027785).



For further information please contact your local Endress+Hauser Sales Center.

System integration

The device can be given a tag name (max. 8 alphanumeric characters)

Description	Option ¹⁾
Measuring point (TAG), see additional spec.	Z1
Bus address, see additional spec.	Z2

1) Product Configurator, order code for "Identification"

Planning instructions, diaphragm seal systems

NOTICE

Incorrect sizing/ordering of diaphragm seal systems

The performance and the permitted range of application of a diaphragm seal system depend on the process isolating diaphragm used, the filling oil, the coupling, the unit design and on the process and ambient conditions present in the individual application.

- ▶ To help you select the right diaphragm seal system for your applications, Endress+Hauser provides its customers with the free "Applicator Sizing Diaphragm Seal" tool, which is available on DVD or at "www.endress.com/applicator".

People for Process Automation Endress+Hauser **EH**

MyApplicator Contact Terms of use Bug report About Help

Applicator > Sizing > Pressure

1 Selection 2 Sizing 3 Configuration

Sizing Diaphragm Seal Dimensioning pressure devices

Sizing Charts Order Code Installation Check Horncurve Conversion Calculator Units Defaults

General parameters

Product Cerabar S PMP75

Hint: Use MyApplicator to define different options. More ...

Transmitter data

Sensor 1bar/100kPa/15psi gauge

Adjusted span 1 000 mbar

Membrane material 316L

Process connection classes All

Transmitter mounting direct

Fill fluid Silicone oil

Process and ambient conditions

	minimum	nominal	maximum	unit
Process temperature	-10	25	100	°C
Ambient temperature	-10	25	60	°C
Static pressure (abs)	900	1 000	2 000	mbar

Measurement accuracy and offset

	% span /10K	mbar/10K
Error due to change in ambient temperature	0.073	0.728
Error due to change in process temperature	0.048	0.477

Calibration offset

	minimum	nominal	maximum	unit
Maximum offset after installation	-4.2	0	6.1	mbar
	-0.4	0	0.6	%span

Performance data

	minimum	nominal	maximum	unit
Response time Tau (T63)	0.2	0.2	0.2	s
Diaphragm deflection	-23	0	15	%

Configurator Print Sizing --> Selection

Add to shop basket

Reset

TAG

Note: Process temperature range / Process pressure limits
The specified range may be reduced by the selected process connection. Observe the pressure temperature dependency. The corresponding values can be found in the standards.

Warnings/Messages

A0021695-EN

- 1 My Applicator - configuration of the Applicator settings
- 2 Applicator help
- 3 Mouse-over help - hover the cursor over these fields for brief information

For more detailed information or the layout of the optimum diaphragm seal solution for your application, please contact your local Endress+Hauser Sales Center.

Applications

Diaphragm seal systems should be used if the process and the device should be separated.

Diaphragm seal systems offer clear advantages in the following instances:

- In the case of extreme process temperatures
- For aggressive media
- In the case of process media that crystallize
- In the case of corrosive or highly various process media or process media with solids content
- In the case of heterogeneous and fibrous process media
- If extreme measuring point cleaning is necessary, or for very humid mounting locations
- If the measuring point is exposed to severe vibrations
- For mounting locations that are difficult to access

Design and operation mode

Diaphragm seals are separating equipment between the measuring system and the process.

A diaphragm seal system consists of:

- A diaphragm seal
- If necessary, a capillary tube or temperature isolator
- Fill fluid
- A pressure transmitter

The process pressure acts via the process isolating diaphragm of a diaphragm seal on the liquid-filled system, which transfers the process pressure onto the sensor of the pressure transmitter.

Endress+Hauser delivers all diaphragm seal systems as welded versions. The system is hermetically sealed, which ensures the highest reliability.

The diaphragm seal determines the application range of the system by:

- The process isolating diaphragm diameter
- The process isolating diaphragm stiffness and material
- The design (oil volume)

diameter of the process isolating diaphragm

The greater the diameter of the process isolating diaphragm (less stiff), the smaller the temperature effect on the measurement result.

Stiffness of the process isolating diaphragm

The stiffness depends on the diameter of the process isolating diaphragm, the material, any existing coating and the thickness and shape of the process isolating diaphragm. The process isolating diaphragm thickness and the shape are determined by the design. The stiffness of a process isolating diaphragm of a diaphragm seal influences the temperature operating range and the measuring error caused by temperature effects.

The new TempC membrane: Highest accuracy and process safety in pressure and differential pressure measurement with diaphragm seals

To measure even more precisely in such applications and to increase process safety, Endress+Hauser has developed the TempC membrane based on a completely revolutionary technology. This diaphragm guarantees the highest level of accuracy and process safety in diaphragm seal applications.

- The very low temperature effect minimizes the influence of fluctuations of both process and ambient temperatures, thus guaranteeing accurate and stable measurements. Measurement inaccuracies caused by temperature are reduced to a minimum.
- The TempC membrane can be used at temperatures between -40 °C (-40 °F) and $+250\text{ °C}$ ($+482\text{ °F}$). This guarantees maximum process safety even for very long sterilization and cleaning cycles (SIP/CIP) in tanks and pipes at high temperatures.
- Thanks to the TempC membrane, smaller dimension process connections are possible. With a smaller process connection, the new diaphragm measures at least as accurately as a conventional diaphragm with a larger diameter.
- Short recovery times after temperature shocks mean less downtime during batch processes and therefore a far higher level of availability of the production facilities.
- In addition, the TempC membrane excels in terms of its improved hygienic cleanability and its insensitivity to substantial changes in the pressure load.

Ordering information:

See the Product Configurator for the individual process connection and the choice of process isolating diaphragm.

Selection in the Applicator:

Under "Transmitter data" in the "Diaphragm material" field.

Capillary

As standard, capillaries with an internal diameter of 1 mm (0.04 in) are used.

The capillary tube influences the thermal change, the ambient temperature operating range and the response time of a diaphragm seal system as a result of its length and internal diameter.

Filling oil

When selecting the filling oil, the media and ambient temperature as well as the operating pressure are of crucial importance. Observe the temperatures and pressures during commissioning and cleaning. A further selection criterion is the compatibility of the filling oil with the requirements of the process media. For this reason, only filling oils that are harmless to health may be used in the food industry, such as vegetable oil or silicone oil (see also the following section on "diaphragm seal filling oils").

The filling oil used influences the thermal change, the temperature operating range of a diaphragm seal system and the response time. A temperature change results in a volume change of the filling oil. The volume change is dependent on the expansion coefficient and on the volume of the filling oil at calibration temperature (constant in range: +21 to +33 °C (+70 to +91 °F)). The application range can be extended by a filling oil with a lower expansion coefficient and a shorter capillary.

For example, the filling oil expands in the event of a temperature increase. The additional volume presses against the process isolating diaphragm of a diaphragm seal. The stiffer a diaphragm is, the greater its return force, which counteracts a volume change and acts on the measuring cell together with the operating pressure, thus shifting the zero point.

Pressure transmitter

The pressure transmitter influences the temperature operating range, the TK zero point and the response time as a result of its volume change. The volume change is the volume that has to be shifted to pass through the complete measuring range.

Pressure transmitters from Endress+Hauser are optimized with regard to minimum volume change.

Diaphragm seal filling oils

Filling oil	Permitted temperature range ¹⁾ at 0.05 bar (0.725 psi) $\leq p_{abs} \leq$ 1 bar (14.5 psi)	Permitted temperature range ¹⁾ at $p_{abs} \geq$ 1 bar (14.5 psi)	Density [g/cm ³] / [SGU]	Viscosity [mm ² /s] / [cSt] at 25 °C (77 °F)	Expansion coefficient ²⁾ [1/K]	Notes	Option ³⁾
Silicone oil	-40 to +180 °C (-40 to +356 °F)	-40 to +250 °C (-40 to +482 °F)	0.96	100	0.00096	(Suitable for use in food FDA 21 CFR 175.105)	A, H, 1 or 2
High-temperature oil	-10 to +200 °C (+14 to +392 °F)	-10 to +400 °C (+14 to +752 °F) ^{4) 5) 6)}	1.00	150	0.00096	(High temperatures)	G, 3 or 4
Inert oil	-40 to +80 °C (-40 to +176 °F)	-40 to +175 °C (-40 to +347 °F)	1.87	27	0.000876	(For ultrapure gas and oxygen applications)	F or N
Vegetable oil	-10 to +120 °C (+14 to +248 °F)	-10 to +200 °C (+14 to +392 °F)	0.94	9.5	0.00101	(Suitable for use in food FDA 21 CFR 172.856)	D, 5 or 6
Low-temperature oil	-70 to +80 °C (-94 to +176 °F)	-70 to +180 °C (-94 to +356 °F)	0.92	4.4	0.00108	(Low temperatures)	7 or 8

1) Observe temperature limits of the device and the system.

2) Please refer to the "Applicator Sizing Diaphragm Seal" selection tool for the thermal change of the diaphragm seal and other important technical features.

3) Product Configurator, order code for "Fill fluid"

4) 325 °C (617 °F) at an absolute pressure of \geq 1 bar (14.5 psi) .

5) 350 °C (662 °F) at an absolute pressure of \geq 1 bar (14.5 psi) (max. 200 hours).

6) 400 °C (752 °F) at an absolute pressure of \geq 1 bar (14.5 psi) (max. 10 hours).

Information on cleaning

- Endress+Hauser provides flushing rings as an accessory to enable cleaning of the process isolating diaphragm without removing the transmitter from the process. For further information please contact your local Endress+Hauser Sales Center.
- We recommend you perform CIP (cleaning in place (hot water)) before SIP (sterilization in place (steam)) for pipe diaphragm seals. A frequent use of sterilization in place (SIP) will increase the stress on the process isolating diaphragm. Under unfavorable circumstances in the long term view we cannot exclude that a frequent temperature change could lead to a material fatigue of the process isolating diaphragm and possibly to a leakage.

Installation instructions**Diaphragm seal systems**

- The diaphragm seal together with the transmitter form a closed, calibrated system, which is filled through ports in the diaphragm seal and in the measuring system of the transmitter. These ports are sealed and must not be opened.
- For devices with a temperature isolator or capillary, a suitable fastening device (mounting bracket) is recommended.
- When mounting, sufficient strain relief must be provided for the capillary line to prevent the capillary from bending (capillary bending radius ≥ 100 mm (3.94 in)).
- For more detailed installation instructions, Endress+Hauser provides its customers with the free "Applicator Sizing Diaphragm Seal" tool, which is available on CD or can be downloaded online at "www.endress.com/applicator".

Capillary

In order to obtain more precise measurement results and to avoid a defect in the device, mount the capillaries as follows:

- vibration-free (in order to avoid additional pressure fluctuations)
- not in the vicinity of heating or cooling lines
- insulate if the ambient temperature is below or above the reference temperature
- with a bending radius ≥ 100 mm (3.94 in)
- When using diaphragm seal systems with a capillary, sufficient strain relief must be provided to prevent the capillary from bending (capillary bending radius ≥ 100 mm (3.94 in)).
- In the case of devices with diaphragm seals and capillaries, the zero point shift caused by the hydrostatic pressure of the filling liquid column in the capillaries must be taken into account when selecting the measuring cell. If a measuring cell with a small measuring range is selected, a position adjustment can cause range violation.

Heat insulation

The PMP75 must only be insulated up to a certain height. The maximum permitted insulation height is indicated on the devices and applies to an insulation material with a heat conductivity ≤ 0.04 W/(m x K) and to the maximum permitted ambient and process temperature. The data were determined under the most critical application "quiescent air". Maximum permitted insulation height, here indicated on a PMP75 with a flange:

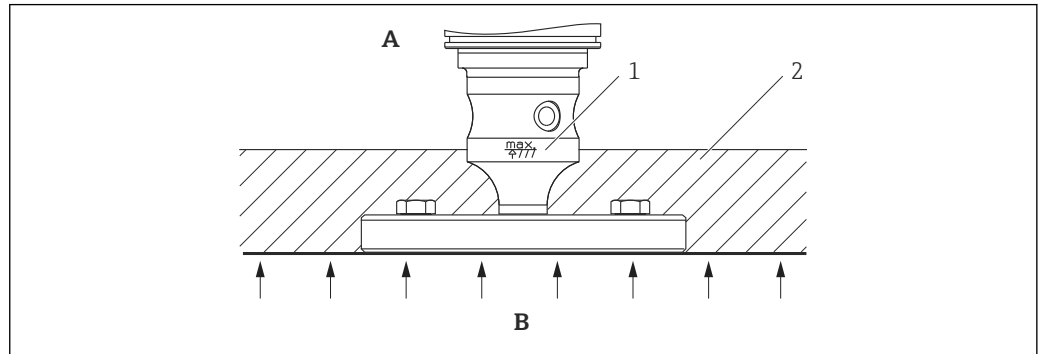

- A Ambient temperature ≤ 70 °C (158 °F)
- B Process temperature max. 400 °C (752 °F), depending on the diaphragm seal filling oil used
- 1 Maximum insulation height
- 2 Insulation material

Mounting with temperature isolator

Endress+Hauser recommends the use of temperature isolators in the event of constant extreme fluid temperatures which cause the maximum permitted electronics temperature of +85 °C (+185 °F) to be exceeded.

Depending on the filling oil used, diaphragm seal systems with temperature isolators can be used up to a maximum of +260 °C (+500 °F).

To minimize the influence of rising heat, Endress+Hauser recommends the device be mounted horizontally or with the housing pointing downwards. The additional installation height also brings about a zero point shift of maximum 21 mbar (0.315 psi) due to the hydrostatic column in the temperature isolator. You can correct this zero point shift at the device.

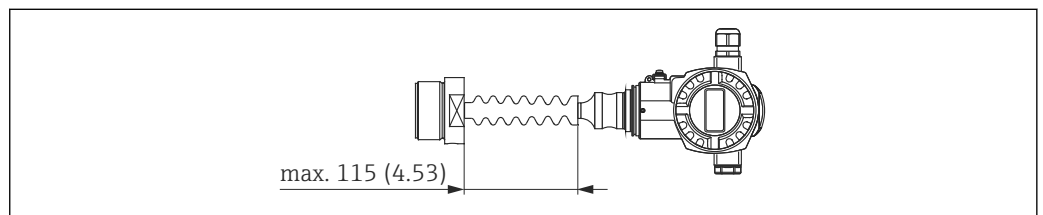

- 1 PMP75 with temperature isolator, material 316L (1.4404)

Vacuum applications

Installation instructions

For applications under vacuum, Endress+Hauser recommends mounting the pressure transmitter below the diaphragm seal. This prevents vacuum loading of the diaphragm seal caused by the presence of fill fluid in the capillary.

When the pressure transmitter is mounted above the diaphragm seal, the maximum height difference H1 in accordance with the illustration below must not be exceeded. The following graphic depicts mounting above the lower diaphragm seal:

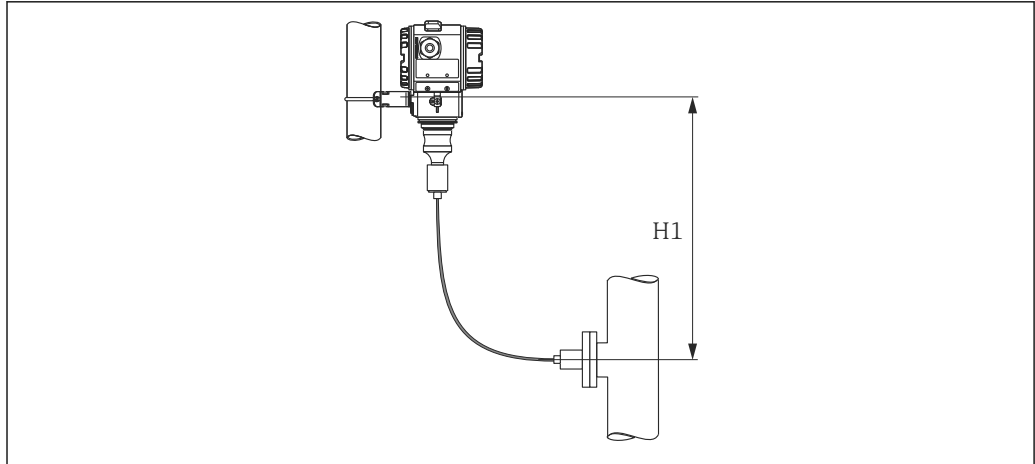

A0020472

The maximum height difference depends on the density of the filling oil and the smallest ever pressure that is permitted to occur at the diaphragm seal (empty container), see the following diagram. The following diagram depicts the maximum installation height above the diaphragm seal for vacuum applications.

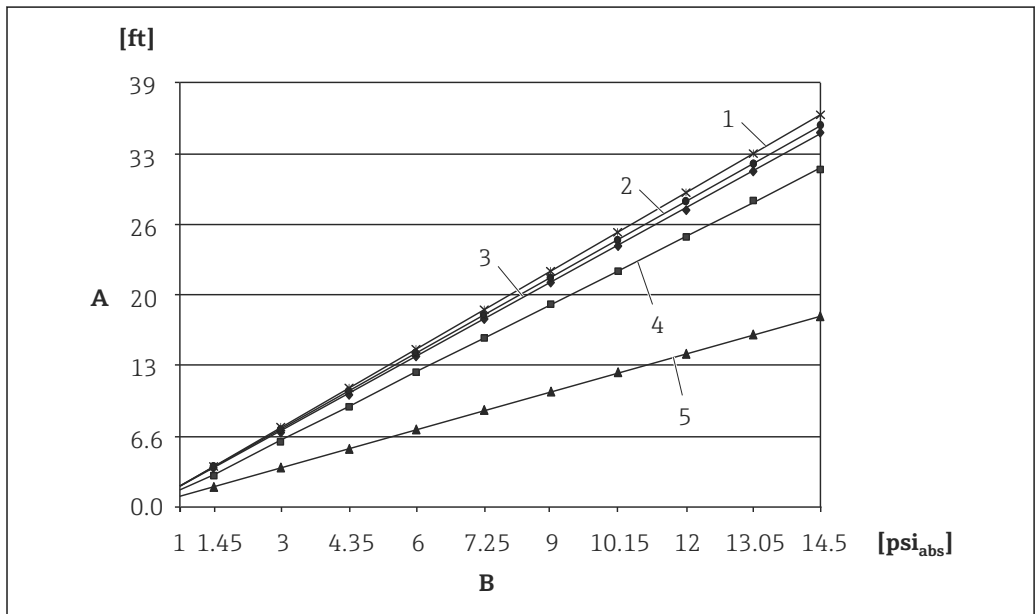

A0023986-EN

- A Height difference H1
- B Pressure at diaphragm seal
- 1 Low-temperature oil
- 2 Vegetable oil
- 3 Silicone oil
- 4 High-temperature oil
- 5 Inert oil

Certificates and approvals

CE mark	The device meets the legal requirements of the relevant EC directives. Endress+Hauser confirms that the device has been successfully tested by applying the CE mark.
C-tick mark	The measuring system complies with EMC requirements of the "Australian Communications and Media Authority (ACMA)".
Ex approvals	<ul style="list-style-type: none"> ▪ ATEX ▪ FM ▪ CSA ▪ NEPSI ▪ IECEX ▪ TIIS ▪ GOST ▪ Also combinations of different approvals <p>All explosion protection data are given in separate documentation which is available upon request. The Ex documentation is supplied as standard with all Ex-systems →  112.</p>

Suitable for hygiene applications All materials in contact with foodstuffs comply with framework regulation (EC) 1935/2004. The device is available with hygienic process connections (overview: see order code).

⚠ CAUTION

Contamination in the process!

Risk of contamination if incorrect seals and parts are used!

- ▶ To avoid the risk of contamination, when installing the device comply with the design principles of EHEDG, Guideline 37 "Hygienic Design and Application of Sensors" and Guideline 16 "Hygienic Pipe Couplings".
- ▶ Suitable assemblies and seals must be used to ensure hygienic design in accordance with 3-A SSI and EHEDG specifications.
- ▶ The leak-proof connections can be cleaned with the cleaning methods typical of this industry (CIP and SIP). Attention must be paid to the pressure and temperature specifications of the sensor and process connections for CIP and SIP processes (clean in place/sterilize in place).



A0026782

 The gap-free connections can be cleaned of all residue using the usual cleaning methods within this industry.

Functional safety SIL/ IEC 61508 Declaration of Conformity (optional) The Cerabar S devices with a 4 to 20 mA output signal have been developed in accordance with the IEC 61508 standard. These devices can be used to monitor the process level and pressure up to SIL 3. For a detailed description of the safety functions with Cerabar S, settings and functional safety data, see the "Functional safety manual - Cerabar S" SD00190P/00.

For devices up to SIL 3 / IEC 61508 Declarations of Conformity see:
Ordering information:
Product Configurator, order code for "Additional options 1" and "Additional options 2", version "E".

Overfill protection WHG (see document ZE00260P/00/DE)

Ordering information:
Product Configurator, order code for "Approval", option "6".

CRN approval

Some device versions have CRN approval. A CRN-approved process connection with a CSA approval must be ordered for a CRN-approved device. These devices are fitted with a separate nameplate with the registration number CRN OF10525.5C .

PMP75 devices with a capillary are not CRN-approved.

Ordering information:
Product Configurator, order code for "Process connection; material" and
Product Configurator, order code for "Approval"

Other standards and guidelines

The applicable European guidelines and standards can be found in the relevant EU Declarations of Conformity. The following were also applied:

DIN EN 60770 (IEC 60770):

Transmitters for use in industrial-process control systems. Part 1: Methods for operating performance evaluation

DIN 16086:

Electrical pressure measuring instruments, pressure sensors, pressure transmitters, pressure measuring instruments, concepts, specifications on data sheets

EN 61326-X:

EMC product family standard for electrical equipment for measurement, control and laboratory use.

EN 60529:

Degrees of protection provided by enclosures (IP code)

WELMEC guide 8.8:

General and Administrative Aspects of the Voluntary System of Modular Evaluation of Measuring instruments under the MID.

OIML R117-1 Edition 2007 (E):

Dynamic measuring systems for liquids other than water.

EN 12405-1/A1 Edition 2006:

Gas meters – Conversion devices – Part 1: Volume conversion

Pressure Equipment Directive (PED)

The device corresponds to Article 3 (3) of the EC directive 97/23/EC (Pressure Equipment Directive) and has been designed and manufactured in accordance with good engineering practice.

The following also applies:

- PMP71 with threaded connection and internal process isolating diaphragm PN > 200 as well as oval flange adapter PN > 200:
Suitable for stable gases in group 1, category I
- PMP75 with pipe diaphragm seal $\geq 1.5"/PN40$:
Suitable for stable gases in group 1, category II
- PMP75 with barriers PN > 200 $\geq 1.5"/PN40$:
Suitable for stable gases in group 1, category I
- PMP75 with threaded connection PN > 200

Marine approval

- GL (German Lloyd)
- ABS

Ordering information:
Product Configurator, order code for "Additional options 1" or "Additional options 2", version "S".

Drinking water approval

PMC71/PMP71: NSF 61 approval

Ordering information:

Product Configurator, order code for "Additional options 1" or Additional options 2", version "F".

Approvals for custody transfer

All aspects of OIML R117-1 Edition 2007 (E) and EN 12405-1/A1 Edition 2006 are fulfilled.

MID Parts Certificate

TC7975

Classification of process sealing between electrical systems and (flammable or combustible) process fluids in accordance with ANSI/ISA 12.27.01

Endress+Hauser devices are designed in accordance with ANSI/ISA 12.27.01. allowing the user to waive the use and save the cost of installing external secondary process seals in the conduit as required by the process sealing sections of ANSI/NFPA 70 (NEC) and CSA 22.1 (CEC). These instruments comply with the North American installation practice and provide a very safe and cost-saving installation for pressurized applications with hazardous fluids. Please refer to the following table for the seal class assigned (single seal or dual seal):

Device	Approval	Remark	Single seal MWP	Dual seal MWP
PMC71	CSA C/US IS, XP	except separate housing	-	60 bar (900 psi)
	CSA C/US IS	With separate housing	40 bar (600 psi)	-
PMP71	CSA C/US XP, XP+IS	except separate housing	400 bar (6 000 psi)	-
	CSA C/US IS	except separate housing	>200 to 400 bar (3 000 to 6 000 psi)	≤200 bar (3 000 psi)
	CSA C/US IS	With separate housing	400 bar (6 000 psi)	-
PMP75	XP, XP+IS	except separate housing	400 bar (6 000 psi)	-
	CSA C/US IS	except separate housing	>200 to 400 bar (3 000 to 6 000 psi)	≤200 bar (3 000 psi)
	CSA C/US IS	With separate housing	400 bar (6 000 psi)	-

Further information can be found in the control drawings of the relevant devices.

Inspection certificate

Description	PMC71	PMP71	PMP75	Option
Material test certificate for wetted components, inspection certificate as per EN10204-3.1 acc. to specification 52005759	✓	✓	✓	B ¹⁾
Declaration of Conformity NACE MR0175, wetted metal parts	—	✓	✓	C ¹⁾
Material test certificate for wetted components as per EN 10204 3.1 and NACE MR0175 material, inspection certificate as per EN10204-3.1 acc. to specification 52010806	—	✓	✓	D ¹⁾
Individual testing with test certificate, inspection certificate as per EN10204-3.1	✓	✓	✓	3 ¹⁾
Overpressure testing with test certificate, inspection certificate as per EN10204-3.1	✓	✓	✓	4 ¹⁾
Helium leak test EN 1518 with test certificate, inspection certificate as per EN10204-3.1	✓	✓	—	5 ¹⁾
EN10204-3.1 material wetted parts +Ra, Ra= surface roughness, dimensional check, inspection certificate	✓	—	—	6 ¹⁾
EN10204-3.1 measurement of delta ferrite content, inspection certificate	✓	—	—	8 ¹⁾
3.1 Material documentation, wetted metal parts, EN10204-3.1 inspection certificate	✓	✓	✓	JA ²⁾
Declaration of Conformity NACE MR0175, wetted metal parts	—	✓	✓	JB ²⁾
Declaration of Conformity NACE MR0103, wetted metal parts	✓	✓	✓	JE
PMI test (XRF), internal procedure, metal parts in contact with the medium	✓	✓	✓	KG
Welding documentation, wetted/pressurized seams	—	✓	—	KS

- 1) Product Configurator, order code for "Additional options 1" and "Additional options 2"
- 2) Product Configurator, order code for "Test, certificate"

Calibration

Description	PMC71	PMP71	PMP75	Option ¹⁾
Sensor range; mbar/bar	✓	✓	✓	1
Sensor range; kPa/MPa	✓	✓	✓	2
Sensor range; mmH ₂ O/mH ₂ O	✓	✓	✓	3
Sensor range; inH ₂ O/ftH ₂ O	✓	✓	✓	4
Sensor range; psi	✓	✓	✓	6
Customer-specific; see additional specification	✓	✓	✓	B
Factory calibration certificate, 5-point; see additional specification	✓	✓	✓	C
DKD/DAkkS certificate; see additional specification	✓	✓	✓	D
Customized pressure; see additional specification	✓	✓	✓	E
Customized level; see additional specification	✓	✓	✓	F
Customized pressure + 5-point factory calibration certificate; see additional specification	✓	✓	✓	H
Customized level + 5-point factory calibration certificate; see additional specification	✓	✓	✓	I
Platinum; see additional specification	✓	✓	—	K
Platinum + factory calibration certificate 5-point; see additional specification	✓	✓	—	L
Platinum + DKD/DAkkS certificate; see additional specification	✓	✓	—	M

1) Product Configurator, order code for "Calibration; unit"

Ordering information

Detailed ordering information is available from the following sources:

- In the Product Configurator on the Endress+Hauser website: www.endress.com → Select country → Products → Select product → Product page function: Configure this product
- From your Endress+Hauser Sales Center: www.endress.com/worldwide

Product Configurator - the tool for individual product configuration

- Up-to-the-minute configuration data
 - Depending on the device: Direct input of information specific to measuring point, e.g. measuring range
 - Automatic verification of exclusion criteria
 - Automatic creation of the order code and its breakdown in PDF or Excel output format
 - Ability to order directly from the Endress+Hauser Online Shop

Scope of delivery

- Measuring device
- Optional accessories
- Brief Operating Instructions
- Certificates

Configuration data sheet

Pressure

The following configuration data sheet must be completed and included with the order if the option "E" or "H" has been selected in the Product Configurator, order code for "Calibration; Unit".

Pressure unit				
<input type="checkbox"/> mbar	<input type="checkbox"/> mmH ₂ O ¹⁾	<input type="checkbox"/> mmHg ²⁾	<input type="checkbox"/> Pascal	<input type="checkbox"/> torr
<input type="checkbox"/> bar	<input type="checkbox"/> mH ₂ O ¹⁾	<input type="checkbox"/> inHg ²⁾	<input type="checkbox"/> hPa	<input type="checkbox"/> g/cm ²
<input type="checkbox"/> psi	<input type="checkbox"/> ftH ₂ O ¹⁾	<input type="checkbox"/> gf/cm ²	<input type="checkbox"/> kPa	<input type="checkbox"/> kg/cm ²
	<input type="checkbox"/> inH ₂ O ¹⁾	<input type="checkbox"/> kgf/cm ²	<input type="checkbox"/> MPa	<input type="checkbox"/> lb/ft ²
				<input type="checkbox"/> atm

- 1) The conversion factor for the pressure unit is based on a reference temperature of 4 °C (39.2 °F).
- 2) The conversion factor of the pressure unit refers to a reference temperature of 0 °C (32 °F).

Calibration range / Output		
Lower range value (LRV):	_____	[pressure unit]
Upper range value (URV):	_____	[pressure unit]

Display
Display of the content of the main line (option depends on sensor and communication variant)
<input type="checkbox"/> Primary value [PV] (default)
<input type="checkbox"/> Primary value [%]
<input type="checkbox"/> Pressure
<input type="checkbox"/> Current [mA] (HART only)
<input type="checkbox"/> Temperature
<input type="checkbox"/> Error number
<input type="checkbox"/> Alternating display

Damping
Damping: _____ sec (Default 2 sec)

Smallest span (factory calibration)

Level

The following configuration data sheet must be completed and included with the order if the option "F" or "T" has been selected in the Product Configurator, order code for "Calibration; Unit".

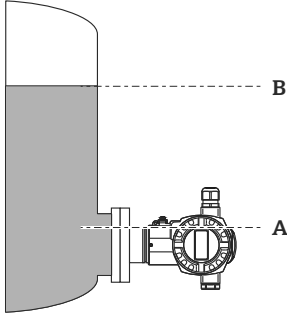
Pressure unit				Output unit (scaled unit)							
<input type="checkbox"/> mbar	<input type="checkbox"/> mmH ₂ O ¹⁾	<input type="checkbox"/> mmHg ²⁾	<input type="checkbox"/> Pascal	<input type="checkbox"/> torr	Mass	Lengths	Volume	Volume	Percent		
<input type="checkbox"/> bar	<input type="checkbox"/> mH ₂ O ¹⁾	<input type="checkbox"/> inHg ²⁾	<input type="checkbox"/> hPa	<input type="checkbox"/> g/cm ²	<input type="checkbox"/> kg	<input type="checkbox"/> m	<input type="checkbox"/> l	<input type="checkbox"/> USgal	<input type="checkbox"/> %		
<input type="checkbox"/> psi	<input type="checkbox"/> ftH ₂ O ¹⁾	<input type="checkbox"/> gf/cm ²	<input type="checkbox"/> kPa	<input type="checkbox"/> kg/cm ²	<input type="checkbox"/> t	<input type="checkbox"/> dm	<input type="checkbox"/> hl	<input type="checkbox"/> impgal			
	<input type="checkbox"/> inH ₂ O ¹⁾	<input type="checkbox"/> kgf/cm ²	<input type="checkbox"/> MPa	<input type="checkbox"/> lb/ft ²	<input type="checkbox"/> lb	<input type="checkbox"/> cm	<input type="checkbox"/> m ³	<input type="checkbox"/> USbbiPE			
				<input type="checkbox"/> atm		<input type="checkbox"/> mm	<input type="checkbox"/> ft ³	TR			
						<input type="checkbox"/> ft					
						<input type="checkbox"/> inch					
Empty calibration [a]: Low pressure value (empty) _____ [pressure unit]				Empty calibration [a]: Low measured value (empty) _____ [Scaled unit]					<p>Example</p>  <p style="text-align: right; font-size: small;">A0020477</p> <p>A 0 mbar/0 m B 300 mbar (4.5 psi) / 3 m (9.8 ft)</p>		
Full calibration [b]: High pressure value (full) _____ [pressure unit]				Full calibration [b]: High level value (full) _____ [Scaled unit]							

- 1) The conversion factor for the pressure unit is based on a reference temperature of 4 °C (39.2 °F).
- 2) The conversion factor of the pressure unit refers to a reference temperature of 0 °C (32 °F).

Display
Display of the content of the main line (option depends on sensor and communication variant)
<input type="checkbox"/> Primary value [PV] (default)
<input type="checkbox"/> Primary value [%]
<input type="checkbox"/> Pressure
<input type="checkbox"/> Current [mA] (HART only)
<input type="checkbox"/> Temperature
<input type="checkbox"/> Level before lin.
<input type="checkbox"/> Tank content
<input type="checkbox"/> Error number
<input type="checkbox"/> Alternating display

Damping
Damping: _____ sec (Default 2 sec)

Accessories

HistoROM®/M-DAT

HistoROM®/M-DAT is a memory module which can be attached to every electronic insert.

Ordering information:

Product Configurator, order code for "Additional options 1" or "Additional options 2", version "N" or as a separate accessory (part no.: 52027785).

Wall and pipe mounting

Endress+Hauser offers a mounting bracket for installing the device on pipes or walls.

Ordering information:

Product Configurator, order code for "Additional options 2", version "U" or as a separate accessory (part no.: 71102216).

Dimensions →  34

Welding flanges and welding neck

For details refer to TI00426F/00/EN "Weld-in adapter and flanges".

Supplementary documentation

Field of Activities	Pressure measurement, powerful instruments for process pressure, differential pressure, level and flow: FA00004P/00/EN
Technical Information	<ul style="list-style-type: none"> ■ EMC test procedures: TI00241F/00/EN ■ Deltabar S: TI00382P/00/EN ■ Deltapilot S: TI00416P/00/EN ■ EMC test procedures: TI00241F/00/EN
Operating Instructions	<p>4 to 20 mA HART:</p> <ul style="list-style-type: none"> ■ Cerabar S: BA00271P/00/EN ■ Description of device functions Cerabar S/Deltabar S/Deltapilot S: BA00274P/00/EN <p>4 to 20 mA HART with MID parts certificate:</p> <ul style="list-style-type: none"> ■ BA00412P/00/EN ■ Description of Device Functions: BA00413P/00/EN <p>PROFIBUS PA:</p> <ul style="list-style-type: none"> ■ Cerabar S: BA00295P/00/EN ■ Description of device functions Cerabar S/Deltabar S/Deltapilot S: BA00296P/00/EN <p>FOUNDATION Fieldbus:</p> <ul style="list-style-type: none"> ■ Cerabar S: BA00302P/00/EN ■ Description of device functions Cerabar S/Deltabar S/Deltapilot S: BA00303P/00/EN
Brief Operating Instructions	<ul style="list-style-type: none"> ■ 4 to 20 mA HART, Cerabar S: KA01019P/00/EN ■ PROFIBUS PA, Cerabar S: KA01022P/00/EN ■ FOUNDATION Fieldbus, Cerabar S: KA01025P/00/EN
Functional safety manual (SIL)	Cerabar S (4 to 20 mA): SD00190P/00/EN
Overfill protection	WHG: ZE00260P/00/DE
Safety Instructions (XA)	Depending on the approval, the following Safety Instructions (XA) are supplied with the device. They are an integral part of the Operating Instructions.

Directive	Device	Electronics	Documentation	Option ¹⁾
ATEX II 1/2 G Ex ia IIC T6	PMC71, PMP71, PMP75	4 to 20 mA HART, PROFIBUS PA, FOUNDATION Fieldbus	XA00244P	1
ATEX II 1/2 D Ex ia	PMP71, PMP75	4 to 20 mA HART, PROFIBUS PA, FOUNDATION Fieldbus	<ul style="list-style-type: none"> ■ XA00246P ■ XA00289P 	2
ATEX II 1/2D Ex tD	PMC71	4 to 20 mA HART, PROFIBUS PA, FOUNDATION Fieldbus	<ul style="list-style-type: none"> ■ XA00247P ■ XA00290P 	2
ATEX II 1/3D Ex tD	PMP71, PMP75	4 to 20 mA HART, PROFIBUS PA, FOUNDATION Fieldbus	<ul style="list-style-type: none"> ■ XA00248P ■ XA00291P 	4
ATEX II 2G Ex d IIC T6 Gb	PMP71, PMP75	4 to 20 mA HART, PROFIBUS PA, FOUNDATION Fieldbus	XA00249P	5
ATEX II 2G Ex d [ia] IIC T6 Gb	PMC71	4 to 20 mA HART, PROFIBUS PA, FOUNDATION Fieldbus	XA00250P	5
ATEX II 1/2G Ex ia IIC T6, WHG (German Water Resources Act)	PMC71, PMP71, PMP75	4 to 20 mA HART, PROFIBUS PA, FOUNDATION Fieldbus	XA00244P	6
ATEX II 3 G Ex nA II T6	PMC71, PMP71, PMP75	4 to 20 mA HART, PROFIBUS PA, FOUNDATION Fieldbus	XA00251P	7
ATEX II 1/2G Ex ia + II 1/2D Ex iaD	PMC71, PMP71, PMP75	4 to 20 mA HART, PROFIBUS PA, FOUNDATION Fieldbus	XA00253P	3

Directive	Device	Electronics	Documentation	Option ¹⁾
ATEX II 1G Ex ia + II 1D Ex iaD	PMC71, PMP71, PMP75	4 to 20 mA HART, PROFIBUS PA, FOUNDATION Fieldbus	XA00276P	8
ATEX II 1/2G Ex ia IIC T6+II 2G Ex d IIC T6	PMP71, PMP75	4 to 20 mA HART, PROFIBUS PA, FOUNDATION Fieldbus	XA00252P	B
ATEX II Ex ia + FM IS + CSA IS ATEX II 1/2G Ex ia IIC T6 + FM/CSA IS Cl.I,II,III Div. 1 Gr.A-G, FM/CSA: Zone 0,1,2	PMC71	<ul style="list-style-type: none"> ▪ 4 to 20 mA HART, PROFIBUS PA, FOUNDATION Fieldbus ▪ HART ▪ PROFIBUS PA, FOUNDATION Fieldbus 	<ul style="list-style-type: none"> ▪ XA00244P ▪ XA00593P + XA01059P ▪ XA00596P + XA01060P 	E
ATEX II Ex ia / Ex d + FM/CSA IS + XP ATEX II 1/2G Ex ia IIC T6+ ATEX II 2G Ex d IIC T6+ FM/CSA IS + XP Cl.I.II Div.1 Gr.A-G/B-G FM: Zone 1.2/CSA: Zone 1,2	PMP71, PMP75	<ul style="list-style-type: none"> ▪ 4 to 20 mA HART, PROFIBUS PA, FOUNDATION Fieldbus ▪ HART ▪ PROFIBUS PA, FOUNDATION Fieldbus 	<ul style="list-style-type: none"> ▪ XA00252P ▪ XA00592P + XA01197P ▪ XA00590P + XA01198P 	F

1) Product Configurator, order code for "Approval"

Directive	Device	Electronics	Documentation	Option ¹⁾
IECEx Zone 0/1 Ex ia IIC T6	PMC71, PMP71, PMP75	4 to 20 mA HART	XB00005P	I
IEC Ex d ia IIC T6 Gb	PMC71	4 to 20 mA HART, PROFIBUS PA, FOUNDATION Fieldbus	XA00511P	B
IEC Ex d IIC T6 Gb	PMP71, PMP75	4 to 20 mA HART, PROFIBUS PA, FOUNDATION Fieldbus	XA00510P	M

1) Product Configurator, order code for "Approval"

Directive	Device	Electronics	Documentation	Option ¹⁾
NEPSI Ex ia IIC T6	PMC71, PMP71, PMP75	4 to 20 mA HART, PROFIBUS PA, FOUNDATION Fieldbus	XA00549P	H
NEPSI Ex d IIC T6	PMP71, PMP75	4 to 20 mA HART, PROFIBUS PA, FOUNDATION Fieldbus	XA00551P	G
NEPSI Ex d ia IIC T6	PMC71	4 to 20 mA HART, PROFIBUS PA, FOUNDATION Fieldbus	XA00551P	G

1) Product Configurator, order code for "Approval"

Directive	Device	Electronics	Documentation	Option ¹⁾
TIIS Ex d ia IIC T6	PMC71	4 to 20 mA HART	TC17436	L
TIIS Ex d ia IIC T4	PMC71	4 to 20 mA HART	TC17398, TC17399	M
TIIS Ex d IIC T6	PMP71 (700 bar version)	4 to 20 mA HART	TC17445	L
TIIS Ex d IIC T6	PMP71, PMP75	4 to 20 mA HART	TC17446	L

1) Product Configurator, order code for "Approval"

Directive	Device	Electronics	Documentation	Option ¹⁾
INMETRO Ex ia IIC T6 Ga/Gb	PMC71, PMP71, PMP75	4 to 20 mA HART, PROFIBUS PA, FOUNDATION Fieldbus	XA01315P	J
INMETRO Ex d IIC T6 Gb	PMP71, PMP75	4 to 20 mA HART, PROFIBUS PA, FOUNDATION Fieldbus	XA01279P	O
INMETRO Ex ta IIIC Da/Db	PMP71, PMP75	4 to 20 mA HART, PROFIBUS PA, FOUNDATION Fieldbus	XA01313P	Z
INMETRO Ex d ia IIC T6 Gb	PMC71	4 to 20 mA HART, PROFIBUS PA, FOUNDATION Fieldbus	XA01280P	P
INMETRO Ex ia IIIC Da/Db	PMC71	4 to 20 mA HART, PROFIBUS PA, FOUNDATION Fieldbus	XA01314P	Z

1) Product Configurator, order code for "Approval"

**Installation/Control
Drawings**

Directive	Device	Electronics	Documentation	Option ¹⁾
FM IS Class I, II, III, Division 1, Groups A – G; NI, Class I Division 2, Groups A – D; AEx ia	PMC71, PMP71, PMP75	<ul style="list-style-type: none"> ■ 4 to 20 mA HART ■ PROFIBUS PA, FOUNDATION Fieldbus 	<ul style="list-style-type: none"> ■ XA01059P ■ XA01060P 	S
CSA IS Class I, II, III, Division 1, Groups A – G; Class I Division 2, Groups A – G	PMC71, PMP71, PMP75	<ul style="list-style-type: none"> ■ 4 to 20 mA HART ■ PROFIBUS PA, FOUNDATION Fieldbus 	<ul style="list-style-type: none"> ■ XA00593P ■ XA00596P 	U
FM IS + XP Class I, Division 1, Groups A – D	PMP71, PMP75	<ul style="list-style-type: none"> ■ 4 to 20 mA HART ■ PROFIBUS PA, FOUNDATION Fieldbus 	<ul style="list-style-type: none"> ■ XA01197P ■ XA01198P 	C
CSA IS + XP Class I Division 1, Groups A – D	PMP71, PMP75	<ul style="list-style-type: none"> ■ 4 to 20 mA HART ■ PROFIBUS PA, FOUNDATION Fieldbus 	<ul style="list-style-type: none"> ■ XA00592P ■ XA00590P 	D
FM/CSA IS + XP Class I Division 1, Groups A – D	PMP71, PMP75	<ul style="list-style-type: none"> ■ 4 to 20 mA HART ■ PROFIBUS PA, FOUNDATION Fieldbus 	<ul style="list-style-type: none"> ■ XA00592P + XA01197P ■ XA01198P + XA00590P 	E
FM NI Cl.I Div.2 Groups A - D, Zone 2	PMC71, PMP71, PMP75	4 to 20 mA HART, PROFIBUS PA, FOUNDATION Fieldbus	XA01063P	R
FM XP Cl.I Div.1 Groups A - D, AEx d, Zone 1,2	PMC71, PMP71, PMP75	4 to 20 mA HART, PROFIBUS PA, FOUNDATION Fieldbus	XA01070P	T
FM DIP Cl.II,III Div.1 Gr.E-G, Zone 21,22	PMP71, PMP75	4 to 20 mA HART, PROFIBUS PA, FOUNDATION Fieldbus	FM3017778	Q
CSA C/US XP Cl.I Div.1 Gr.B-D, Ex d, Zone 1,2	PMC71, PMP71, PMP75	4 to 20 mA HART, PROFIBUS PA, FOUNDATION Fieldbus	ZD00230P + XA00599P	V
CSA C/US General Purpose	PMD75, FMD77, FMD78	4 to 20 mA HART, PROFIBUS PA, FOUNDATION Fieldbus	-	X

1) Product Configurator, order code for "Approval"

Registered trademarks

HART®	Registered trademark of the HART Communication Foundation, Austin, USA
PROFIBUS®	Registered trademark of the PROFIBUS User Organization, Karlsruhe, Germany
FOUNDATION™ Fieldbus	Registered trademark of the Fieldbus Foundation, Austin, Texas, USA

Patents

This product is protected by at least one of the following patents. Further patents are pending.

DE patents	US patents	EP patents
-	US 5,836,063 A1	EP 0 797 084 B1
-	US 5,877,424 A1	EP 0 780 674 B1
DE 203 05 869 U1	-	-
-	US 6,363,790 A1	EP 0 995 979 B1
-	US 5,670,063 A1	EP 0 516 579 B1
-	US 5,539,611 A1	-
-	US 5,050,034 A1	EP 0 445 382 B1
-	US 5,005,421 A1	EP 0 351 701 B1
-	-	EP 0 414 871 B1
-	-	EP 1 061 351 B1
-	US 5,334,344 A1	EP 0 490 807 B1
-	US 6,703,943 A1	-



71306211

www.addresses.endress.com
